



Support your local merchants

AGENDA
TOWN OF CAMP VERDE – PLANNING & ZONING COMMISSION
REGULAR SESSION
473 S. MAIN STREET, SUITE 106
THURSDAY, APRIL 13, 2023, at 6:00 P.M.

ZOOM MEETING LINK:

<https://us06web.zoom.us/j/84620757891?pwd=ZXhseWVXUWYxc3pXRnZEWjA3dDZHZz09>

One Tap Mobile: 1-669-900-9128 or 1-253-215-8782
Meeting ID: 846 2075 7891
Passcode: 766870

1. **Call to Order**
2. **Roll Call.** Chairman Andrew Faiella, Vice Chairman Todd Scantlebury
Greg Blue, Robert Foreman, Ingrid Osses, William Tippet, Mike Hough,
3. **Pledge of Allegiance**
4. **Consent Agenda** - All items listed below may be enacted upon by one motion and approved as Consent Agenda Items. Any item may be removed from the Consent Agenda and considered as a separate item if a member of the Commission so requests.
 - a. **Approval of Minutes:**

March 23, 2023, Regular Session
 - b. **Set Next Meeting, Date and Time:**

April 26, 2023 @ 5:30 pm, Joint Work Session with Town Council
April 27, 2023 @ 6:00 pm, Regular Session
May 11, 2023 @ 6:00 pm, Regular Session
May 25, 2023 @ 6:00 pm, Regular Session
5. **Call to the Public for items not on the agenda** - Residents are encouraged to comment about any matter not included on the agenda. State law prevents the Commission from taking any action on items not on the agenda, except to set them for consideration at a future date.

6. **Discussion Item: Continued from March 23, 2023.** Discussion, consideration, and possible recommendation to the Mayor and Common Council for approval of Final Site Plan for two (2) development sites located within High View at Boulder Creek Planned Area Development (PAD), zoned C3-PAD (Commercial: Heavy Commercial – Planned Area Development) and C2-PAD (Commercial: General Sales and Services – Planned Area Development), specifically site plans for Zane Grey at High View RV Park located on parcel 403-15-003V, Zane Grey at High View Multi-Family and Commercial on parcel 403-15-003U, Camp Verde, Yavapai County, Arizona.

Staff Resource: Cory Mulcaire

7. **Public Hearing:** Discussion, consideration and possible recommendation to the Mayor and Common Council of the Town of Camp Verde, Yavapai County, Arizona for approval of an Agritourism Use Permit Application for Trampus and Bonnie Mansker for a roping arena located on parcels 404-12-422D and 404-12-422C.

Staff Resource: John Knight

- **Staff Comments**
- **Open Public Hearing**
- **Close Public Hearing**
- **Commission Discussion**

8. **Current Events** - Individual members of the Commission may provide brief summaries of current events and activities. These summaries are strictly for the purpose of informing the public of such events and activities. The Commission will take no discussion, consideration, or action on any such item, except that an individual Commission member may request an item be placed on a future agenda.

9. **Staff Comments**

10. **Adjournment**

The Planning and Zoning Staff makes every attempt to provide a complete agenda packet for public review. However, it is not always possible to include all information in the packet. You are encouraged to check with the Community Development Department prior to a meeting for copies of supporting documentation, if any that were unavailable at the time agenda packets were prepared.

Note: Pursuant to A.R.S. §38-431.03A.2 and A.3, the Planning & Zoning Commission may vote to go into Executive Session for purposes of consultation for legal advice with the Town Attorney on any matter listed on the Agenda, or discussion of records exempt by law from public inspection associated with an agenda item. The Town of Camp Verde Council Chambers is accessible to the handicapped. Those with special accessibility or accommodation needs, such as large typeface print, may request these at the Office of the Town Clerk.

CERTIFICATION OF POSTING OF NOTICE

The undersigned hereby certifies that a copy of the foregoing notice was duly posted at the Town of Camp Verde and Bashas on April 6, 2023 (date) at 10:00 AM (time) in accordance with the statement filed by the Camp Verde Town Council with the Town Clerk
(signed) Cory L. Mulcaire, _____ Cory Mulcaire, Planner _____ (print name and title)

FINAL MINUTES
REGULAR SESSION
THE PLANNING AND ZONING COMMISSION
TOWN OF CAMP VERDE 473 S. MAIN STREET
CAMP VERDE, AZ. 86322
COUNCIL CHAMBERS STE. 106
THURSDAY, MARCH 23, 2023
6:00 PM

1. Call to Order

Chairman Faiella called the meeting to order at 6:02 p.m.

2. Roll Call

Chairman Andrew Faiella, Vice Chairman Todd Scantlebury, Commissioners Greg Blue, William Tippet and Ingrid Osses were present. Commissioner Mike Hough and Robert Foreman are absent.

Also Present

Community Development Director John Knight, Town Planner Cory Mulcaire and Recording Secretary Jennifer Reed.

3. Pledge of Allegiance

Chairman Faiella led the Pledge.

4. Consent Agenda - All those items listed below may be enacted upon by one motion and approved as Consent Agenda Items. Any item may be removed from the Consent Agenda and considered as a separate item if a member of Commission so requests.

A. Approval of Minutes: November 3, 2022, Special Session
December 1, 2022, Regular Session
January 19, 2023, Regular Session
February 9, 2023, Work Session

B. Set Meeting Dates: April 13, 2023, at 6:00 pm Regular Session
April 26, 2023, at 5:30 pm Joint Session with Town Council
April 27, 2023, at 6:00 pm Regular Session - Canceled
May 11, 2023, at 6:00 pm Regular Session

Motion was made by Commissioner Blue to accept the minutes as presented. Second was made by Vice Chairman Scantlebury. Vice Chair Scantlebury would like Commissioner Blue to amend his motion to correct the minutes for December 1, 2022. He said on page 7, under Item 12, the second sentence of the motion should read, *"In order to ensure and preserve **meeting** meaning and intent of zoning ordinances, Scrivener and formatting error corrections will be forwarded as resolutions to be considered by Council."* **Motion** was made by Commissioner Blue to amend his motion to add the corrections to the minutes of December 1, 2023 as noted by Vice Chair Scantlebury. Second by Commissioner Osses.

Roll Call:

Chairman Andrew Faiella: aye
Vice Chairman Todd Scantlebury: aye
Commissioner Greg Blue: aye
Commissioner Mike Hough: absent
Commissioner Bill Tippet: aye
Commissioner Ingrid Osses: aye
Commissioner Robert Foreman: absent
Motion passed unanimously 5-0.

Motion was made by Commissioner Tippett to accept the next meeting dates and time. Second was made by Commissioner Osses.

Roll Call:

Chairman Andrew Faiella: aye
Vice Chairman Todd Scantlebury: aye
Commissioner Greg Blue: aye
Commissioner Mike Hough: absent
Commissioner Bill Tippett: aye
Commissioner Ingrid Osses: aye
Commissioner Robert Foreman: absent

Motion passed unanimously 5-0.

5. Call to the Public for Items Not on the Agenda

Residents are encouraged to comment about any matter not included on the agenda. State law prevents the Commission from taking any action on items not on the agenda, except to set them for consideration at a future date.

No public to speak.

6. Decision Item: Discussion, Consideration and Possible Recommendation of Site Plan Approval to the Mayor and Council for Partial Development of Verde Commercial property zoned C2-PAD (Commercial: General Sales and Service - Planned Area Development). Site plan includes a 12,800 square foot UPS Logistics Center on Parcel 403-22-035P, Camp Verde, Yavapai County, Arizona. Staff Resource: Cory Mulcaire

Town Planner Cory Mulcaire reviewed the site plan, location and details. This meets the C2 PAD criteria. She also said that Justin Gregonis, with Upward Architects is attending via Zoom if Commissioners have questions.

Applicant Comment

Justin Gregonis with Upward Architects gave an overview on the progress and the timeline for next steps.

Motion was made by Commissioner Blue for Site Plan Approval to the Mayor and Council for Partial Development of Verde Commercial property zoned C2-PAD (Commercial: General Sales and Service - Planned Area Development). Site plan includes a 12,800 square foot UPS Logistics Center on Parcel 403-22-035P, Camp Verde, Yavapai County, Arizona. Second was made by Commissioner Osses.

Roll Call:

Chairman Andrew Faiella: aye
Vice Chairman Todd Scantlebury: aye
Commissioner Greg Blue: aye
Commissioner Mike Hough: absent
Commissioner Bill Tippett: aye
Commissioner Ingrid Osses: aye
Commissioner Robert Foreman: absent

Motion passed unanimously 5-0.

7. Decision Item: Discussion, Consideration, and Possible Recommendation to the Mayor and Common Council for approval of Final Site Plans for two (2) development sites located within High View at Boulder Creek Planned Area Development (PAD), zoned C3-PAD (Commercial: heavy commercial – Planned Area Development) and C2-PAD (Commercial: General Sales and Service – Planned Area Development), specifically Site Plans for Zane Grey at High View RV Park located on parcel 403-15-003V, Zane Grey at High View Multi-Family and Commercial on parcel 403-15-003U, Camp Verde, Yavapai County, Arizona. Staff Resource: Cory Mulcaire

Town Planner Cory Mulcaire reviewed the details for each of the Site Plans. She said the applicant was unable to make tonight's meeting.

Commissioners asked about the sewer system. Mr. Knight said they have multiple options for sewer systems but will working out the details. Ms. Mulcaire stated he will not get a building permit without an approved sewer disposal system from the county.

Commissioners discussed "Open Spaces". It doesn't appear there is a lot of "Open Spaces" shown on the map. Commissioners are very concerned about this.

Motion was made by Commissioner Tippet to recommend to the Mayor and Common Council of the Town of Camp Verde, Yavapai County, Arizona to approve Final Site Plans for two (2) development sites located within High View at Boulder Creek Planned Area Development (PAD), zoned C3-PAD (Commercial: Heavy Commercial – Planned Area Development) and C2-PAD (Commercial: General Sales and Service – Planned Area Development), specifically Site Plans for Zane Grey at High View RV Park located on parcel 403-15-003V, Zane Grey at High View Multi-Family and Commercial on parcel 403-15-003U, Camp Verde, Yavapai County, Arizona. Second was made Chairman Faiella.

Commissioners again discussed Open Spaces. They are concerned there is a lot planned for a small space. Mr. Knight stated 25% is not required, it is preferred. There are other opportunities to provide open space. Vice Chair Scantlebury expects to see more open spaces.

Roll Call:

Chairman Andrew Faiella: aye
Vice Chairman Todd Scantlebury: abstain
Commissioner Greg Blue: nay
Commissioner Mike Hough: absent
Commissioner Bill Tippet: aye
Commissioner Ingrid Osses: aye
Commissioner Robert Foreman: absent

Motion failed 3 ayes- 1 abstain- 1 nay.

Commissioners would like to see more information on sewer and open spaces before approving this Item. Mr. Knight would like to give the applicant time to answer questions at the meeting. He recommends tabling this Item until the next regular meeting scheduled for April 13th.

Motion was made by Vice Chairman Scantlebury to table this item until the next regular meeting April 13, 2023 pending 2 points: 1) sewer handling and 2) open spaces in overall PAD. The entire PAD to be presented by applicant. Second was made by Commissioner Osses.

Roll Call:

Chairman Andrew Faiella: aye
Vice Chairman Todd Scantlebury: aye
Commissioner Greg Blue: aye
Commissioner Mike Hough: absent
Commissioner Bill Tippet: aye
Commissioner Ingrid Osses: aye
Commissioner Robert Foreman: absent

Motion passed unanimously 5-0.

8. Current Events:

Individual members of the Commission may provide brief summaries of current events and activities. These summaries are strictly for the purpose of informing the public of such events and activities. The Commission will take no discussion, consideration, or action on any such item, except that an individual Commission member may request an item be placed on a future agenda.

Chairman Faiella would like Commissioners to plan to attend the visiting Vietnam Wall Event next weekend.

9. Staff Comments:

John Knight-

- The Town has been dealing with flood evacuations and flooding issues. Various agencies are out in the community doing assessments.
- Town Planner BJ Ratlief has been working on sign ordinances. A Joint Work Session with Council will be scheduled soon.
- There will be a pre-session tour on April 13th at 4pm before the next regular meeting. An agenda will be posted and treated as a meeting.
- Board of Adjustment Appeals will be considering *animal unit count* and variances at their next meeting.

11. Adjournment:

Motion made by Commissioner Blue to adjourn the meeting. Second was made by Commissioner Osses.

Roll Call:

Chairman Andrew Faiella: aye

Vice Chairman Todd Scantlebury: aye

Commissioner Greg Blue: aye

Commissioner Mike Hough: absent

Commissioner Bill Tippett: aye

Commissioner Ingrid Osses: aye

Commissioner Robert Foreman: absent

Motion passed unanimously 5-0.

Meeting was adjourned at 6:55 p.m.

Chairman Drew Faiella

Community Development Director John Knight

CERTIFICATION

I hereby certify that the foregoing minutes are a true and accurate accounting of the actions of the Planning & Zoning Commission of the Town of Camp Verde, Arizona during the Regular Session held on the 23rd day of March 2023. I further certify that the meeting was duly called and held and that a quorum was present.

Dated this 23rd day of March 2023.

Jennifer Reed

Jennifer Reed, Recording Secretary



Agenda Report Form – Section I

Meeting Date: Planning and Zoning Commission; Thursday, April 13, 2023

- Consent Agenda
- Decision Agenda
- Executive Session Requested
- Presentation Only
- Action/Presentation
- Work Session

Requesting Department: Community Development

Staff Resource/Contact Person: Cory Mulcaire, Planner

Agenda Title: Discussion, Consideration, and Possible Recommendation to the Mayor and Common Council for approval of Final Site Plans for two (2) development sites located within High View at Boulder Creek Planned Area Development (PAD), zoned C3-PAD (Commercial: Heavy Commercial – Planned Area Development) and C2-PAD (Commercial: General Sales and Service – Planned Area Development), specifically Site Plans for Zane Grey at High View RV Park located on parcel 403-15-003V, Zane Grey at High View Multi-Family and Commercial on parcel 403-15-003U, Camp Verde, Yavapai County, Arizona.

Staff Resource: Cory Mulcaire

List Attached Documents:

- A. DRAFT Minutes Excerpt from 3/23/2023 P&Z meeting
- B. RV Park Landscape Plan
- C. Commercial and MF Landscape Plan
- D. Aqua Tech Info

Estimated Presentation Time: 10 minutes

Estimated Discussion Time: 10 minutes

Background and Discussion: At the previous commission meeting on March 23, 2023, the commissioners requested additional information be provided related to sewer and open space. Due to a miscommunication, the applicant was not available to answer the commissioner’s questions. The commission made a motion to recommend approval (which failed) then a second motion was made to table the item to the next regular meeting (April 13, 2023).

The motion approved 5-0 by the commission is as follows:

Motion was made by Vice Chairman Scantlebury to table this item until the next regular meeting April 13, 2023 pending 2 points: 1) sewer handling and 2) open spaces in overall PAD. The entire PAD to be presented by applicant. Second was made by Commissioner Osses.

Please note that the entire staff report and attachments from the March 23, 2023 are not included in this packet. This information can be obtained by contacting staff or by referring to the town website - <https://www.campverde.az.gov/departments/boards-commissions/planning-zoning-commission>

The applicant has been notified of the meeting and is prepared to answer questions about sewer and open space. In preparation for the meeting, the applicant has provided calculations of open space from the landscape plans. This information is included in Attachments B and C. The applicant has also provided information on the proposed “package plant” sewer system called an Aqua Tech system.

Code Compliance: There are two issues that the commission requested clarification on. One relates to the provision of open space and the other relates to the provision of sewer facilities. These are discussed below.

Open Space – Section 203.L.(2)d. The Zoning Ordinance the PAD section related to the provision of Open Space. This section states:

“Open Space Dedication: open space shall be included in all developments. A dedication of open space not less than twenty-five percent (25%) of a development project is preferred.”

Open Space is also mentioned in the purpose section of 203.L.(1). This section states,

“The greater flexibility in locating buildings and combining compatible uses make it possible to achieve economies of construction as well as preserving open space.”

Note that the language in the ordinance states that the 25% open space is preferred, not required. To further muddy the issue, the zoning ordinance does not define the term open space. The definition of open space is subject to interpretation by the commission and the applicant. For calculation purposes, the applicant has included everything besides pavement or buildings in the open space calculations.

Based on the applicant’s definition, they have provided the following calculations:

- RV Park – 876,407 square feet (this is 56% of the RV parcel)
- Multi-family Area – 498,756 square feet (this is 44% of the MF parcel)
- Commercial Area – 203,214 square feet (this is 48% of the Comm. parcel)

Sewer: The zoning ordinance section related to PADs is silent on the issue of provision of utilities. As a courtesy, the applicant has provided information on the proposed system, included as Attachment D.

Recommended Action: Motion to recommend to the Mayor and Common Council for approval of Final Site Plans for two (2) development sites located within High View at Boulder Creek Planned Area Development (PAD), zoned C3-PAD (Commercial: Heavy Commercial – Planned Area Development) and C2-PAD (Commercial: General Sales and Service – Planned Area Development), specifically Site Plans for Zane Grey at High View RV Park located on parcel 403-15-003V, Zane Grey at High View Multi-Family and Commercial on parcel 403-15-003U, Camp Verde, Yavapai County, Arizona.

Roll Call:

Chairman Andrew Faiella: aye
Vice Chairman Todd Scantlebury: aye
Commissioner Greg Blue: aye
Commissioner Mike Hough: absent
Commissioner Bill Tippet: aye
Commissioner Ingrid Osses: aye
Commissioner Robert Foreman: absent

Motion passed unanimously 5-0.

5. Call to the Public for Items Not on the Agenda

Residents are encouraged to comment about any matter not included on the agenda. State law prevents the Commission from taking any action on items not on the agenda, except to set them for consideration at a future date.

No public to speak.

6. Decision Item: Discussion, Consideration and Possible Recommendation of Site Plan Approval to the Mayor and Council for Partial Development of Verde Commercial property zoned C2-PAD (Commercial: General Sales and Service - Planned Area Development). Site plan includes a 12,800 square foot UPS Logistics Center on Parcel 403-22-035P, Camp Verde, Yavapai County, Arizona. Staff Resource: Cory Mulcaire

Town Planner Cory Mulcaire reviewed the site plan, location and details. This meets the C2 PAD criteria. She also said that Justin Gregonis, with Upward Architects is attending via Zoom if Commissioners have questions.

Applicant Comment

Justin Gregonis with Upward Architects gave an overview on the progress and the timeline for next steps.

Motion was made by Commissioner Blue for Site Plan Approval to the Mayor and Council for Partial Development of Verde Commercial property zoned C2-PAD (Commercial: General Sales and Service - Planned Area Development). Site plan includes a 12,800 square foot UPS Logistics Center on Parcel 403-22-035P, Camp Verde, Yavapai County, Arizona. Second was made by Commissioner Osses.

Roll Call:

Chairman Andrew Faiella: aye
Vice Chairman Todd Scantlebury: aye
Commissioner Greg Blue: aye
Commissioner Mike Hough: absent
Commissioner Bill Tippet: aye
Commissioner Ingrid Osses: aye
Commissioner Robert Foreman: absent

Motion passed unanimously 5-0.

7. Decision Item: Discussion, Consideration, and Possible Recommendation to the Mayor and Common Council for approval of Final Site Plans for two (2) development sites located within High View at Boulder Creek Planned Area Development (PAD), zoned C3-PAD (Commercial: heavy commercial – Planned Area Development) and C2-PAD (Commercial: General Sales and Service – Planned Area Development), specifically Site Plans for Zane Grey at High View RV Park located on parcel 403-15-003V, Zane Grey at High View Multi-Family and Commercial on parcel 403-15-003U, Camp Verde, Yavapai County, Arizona. Staff Resource: Cory Mulcaire

Town Planner Cory Mulcaire reviewed the details for each of the Site Plans. She said the applicant was unable to make tonight's meeting.

Commissioners asked about the sewer system. Mr. Knight said they have multiple options for sewer systems but will working out the details. Ms. Mulcaire stated he will not get a building permit without an approved sewer disposal system from the county.

Commissioners discussed "Open Spaces". It doesn't appear there is a lot of "Open Spaces" shown on the map. Commissioners are very concerned about this.

Motion was made by Commissioner Tippet to recommend to the Mayor and Common Council of the Town of Camp Verde, Yavapai County, Arizona to approve Final Site Plans for two (2) development sites located within High View at Boulder Creek Planned Area Development (PAD), zoned C3-PAD (Commercial: Heavy Commercial – Planned Area Development) and C2-PAD (Commercial: General Sales and Service – Planned Area Development), specifically Site Plans for Zane Grey at High View RV Park located on parcel 403-15-003V, Zane Grey at High View Multi-Family and Commercial on parcel 403-15-003U, Camp Verde, Yavapai County, Arizona. Second was made Chairman Faiella.

Commissioners again discussed Open Spaces. They are concerned there is a lot planned for a small space. Mr. Knight stated 25% is not required, it is preferred. There are other opportunities to provide open space. Vice Chair Scantlebury expects to see more open spaces.

Roll Call:

Chairman Andrew Faiella: aye
Vice Chairman Todd Scantlebury: abstain
Commissioner Greg Blue: nay
Commissioner Mike Hough: absent
Commissioner Bill Tippet: aye
Commissioner Ingrid Osses: aye
Commissioner Robert Foreman: absent

Motion failed 3 ayes- 1 abstain- 1 nay.

Commissioners would like to see more information on sewer and open spaces before approving this Item. Mr. Knight would like to give the applicant time to answer questions at the meeting. He recommends tabling this Item until the next regular meeting scheduled for April 13th.

Motion was made by Vice Chairman Scantlebury to table this item until the next regular meeting April 13, 2023 pending 2 points: 1) sewer handling and 2) open spaces in overall PAD. The entire PAD to be presented by applicant. Second was made by Commissioner Osses.

Roll Call:

Chairman Andrew Faiella: aye
Vice Chairman Todd Scantlebury: aye
Commissioner Greg Blue: aye
Commissioner Mike Hough: absent
Commissioner Bill Tippet: aye
Commissioner Ingrid Osses: aye
Commissioner Robert Foreman: absent

Motion passed unanimously 5-0.

8. Current Events:

Individual members of the Commission may provide brief summaries of current events and activities. These summaries are strictly for the purpose of informing the public of such events and activities. The Commission will take no discussion, consideration, or action on any such item, except that an individual Commission member may request an item be placed on a future agenda.

Chairman Faiella would like Commissioners to plan to attend the visiting Vietnam Wall Event next weekend.

ATTACHMENT B - RV Park Landscape Plan

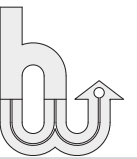
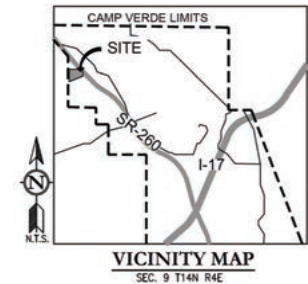

landscape architecture
2901 e. highland ave
phoenix, az 85016
480-686-2001



03.17.23
Entry Update

PLANT LEGEND

SYMBOL	BOTANICAL NAME	COMMON NAME	SIZE	QTY	COMMENTS
Deciduous Accent Trees					
(Symbol)	<i>Chilopsis linearis</i> 'Bubba'	Seedless Desert Willow	25 Gal.	28	Multi Trunk, Dense Canopy
(Symbol)	<i>Prunus</i> spp.	Purple Leaf Plum	25 Gal.	51	Multi Trunk, Dense Canopy
(Symbol)	<i>Vitex agnus-castus</i>	Vitex	15 Gal.	22	Multi Trunk, Dense Canopy
Deciduous Shade Trees					
(Symbol)	<i>Fraxinus velutina</i>	Arizona Ash	15 Gal.	11	Standard Trunk, Dense Canopy
(Symbol)	<i>Gleditsia</i> hybrid	Skyline or Shademaster Honey Locust	25 Gal.	30	Multi Trunk, Dense Canopy
(Symbol)	<i>Pistacia chinensis</i>	Chinese Pistache	15 Gal.	80	Standard Trunk, Dense Canopy
(Symbol)	<i>Platanus</i> 'Bloodgood'	'Bloodgood' Sycamore	25 Gal.	58	Standard Trunk, Dense Canopy
(Symbol)	<i>Prosopis velutina</i>	Velvet Mesquite	24" Box	27	Multi Trunk, Dense Canopy
EVERGREEN SHADE TREES					
(Symbol)	<i>Quercus</i> spp	Oak	25 Gal.	53	Standard Trunk, Dense Canopy
EVERGREEN SCREEN TREES					
(Symbol)	<i>Cedrus deodara</i>	Deodar Cedar	6' B&B	6	Standard Trunk, Dense Canopy
(Symbol)	<i>Cupressus arizonica</i>	Arizona Cypress	25 Gal.	39	Standard Trunk, Dense Canopy
(Symbol)	<i>Pinus eldarica</i>	Afghan Pine	25 Gal.	21	Standard Trunk, Dense Canopy
SHRUBS					
(Symbol)	<i>Anisacanthus thurberi</i>	Desert Honeysuckle	5 Gal	19	Per Plan
(Symbol)	<i>Caesalpinia gilliesii</i>	Yellow Bird of Paradise	5 Gal	28	Per Plan
(Symbol)	<i>Calliandra eriophylla</i>	Pink Fairy Duster	5 Gal	37	Per Plan
(Symbol)	<i>Dalea pulchra</i>	Bush Dalea	5 Gal	18	Per Plan
(Symbol)	<i>Leucophyllum</i> Species	Sage	1 Gal	1,962	Per Plan
(Symbol)	<i>Mahonia aquifolium</i>	Oregon Grape	5 Gal	49	Per Plan
(Symbol)	<i>Photinia x fraseri</i>	Red Tip Photinia	5 Gal	228	Per Plan
(Symbol)	<i>Rhus trilobata</i>	Three Leaf Sumac	5 Gal	21	Per Plan
(Symbol)	<i>Salvia greggii</i>	Autumn Sage	5 Gal	79	Per Plan
(Symbol)	<i>Simmondsia chinensis</i>	Jojoba	5 Gal	31	Per Plan
(Symbol)	<i>Vauquelinia californica</i>	Arizona Rosewood	5 Gal	18	Per Plan
GRASSES					
(Symbol)	<i>Aristida purpurea</i>	Purple Three Awn	15 Gal	70	Per Plan
(Symbol)	<i>Muhlenbergia rigens</i>	Deer Grass	5 Gal	77	Per Plan
ACCENTS					
(Symbol)	<i>Agave</i> spp.	Agave As Selected	5 Gal	30	Per Plan
(Symbol)	<i>Dasylirotion wheeleri</i>	Desert Spoon	5 Gal	18	Per Plan
(Symbol)	<i>Hesperaloe parviflora</i>	Red Yucca	5 Gal	227	Per Plan
(Symbol)	<i>Opuntia violacea</i>	Purple Prickly Pear	5 Gal	12	Per Plan
(Symbol)	<i>Yucca baccata</i>	Banana Yucca	5 Gal	7	Per Plan
GROUND COVERS					
(Symbol)	<i>Dalea greggii</i>	Creeping Dalea	1 Gal	101	Per Plan
(Symbol)	<i>Ericameria laricifolia</i>	Turpentine Bush	1 Gal	67	Per Plan
(Symbol)	<i>Krascheninnikovia lanata</i>	Winterfat	1 Gal	12	Per Plan
(Symbol)	<i>Mahonia repens</i>	Creeping Oregon Grape	1 Gal	16	Per Plan
(Symbol)	<i>Penstemon</i> spp.	Penstemon As Selected	1 Gal	28	Per Plan
(Symbol)	<i>Rosmarinus 'prostratus'</i>	Creeping Rosemary	1 Gal	82	Per Plan
MISCELLANEOUS					
DG	Decomposed Granite - Size: 1/2" Screened Color: 'Mahogany Brown' by RockPro 2" depth in all planting areas (Typ)				
DG PATH	Stabilized DG Pathway - Size: 1/4" Minus Color: 'Mahogany Brown' by RockPro 2" compacted depth				
GRASS	Grass- Sod				
TURF	Turf Playground Soft Fall Surface				

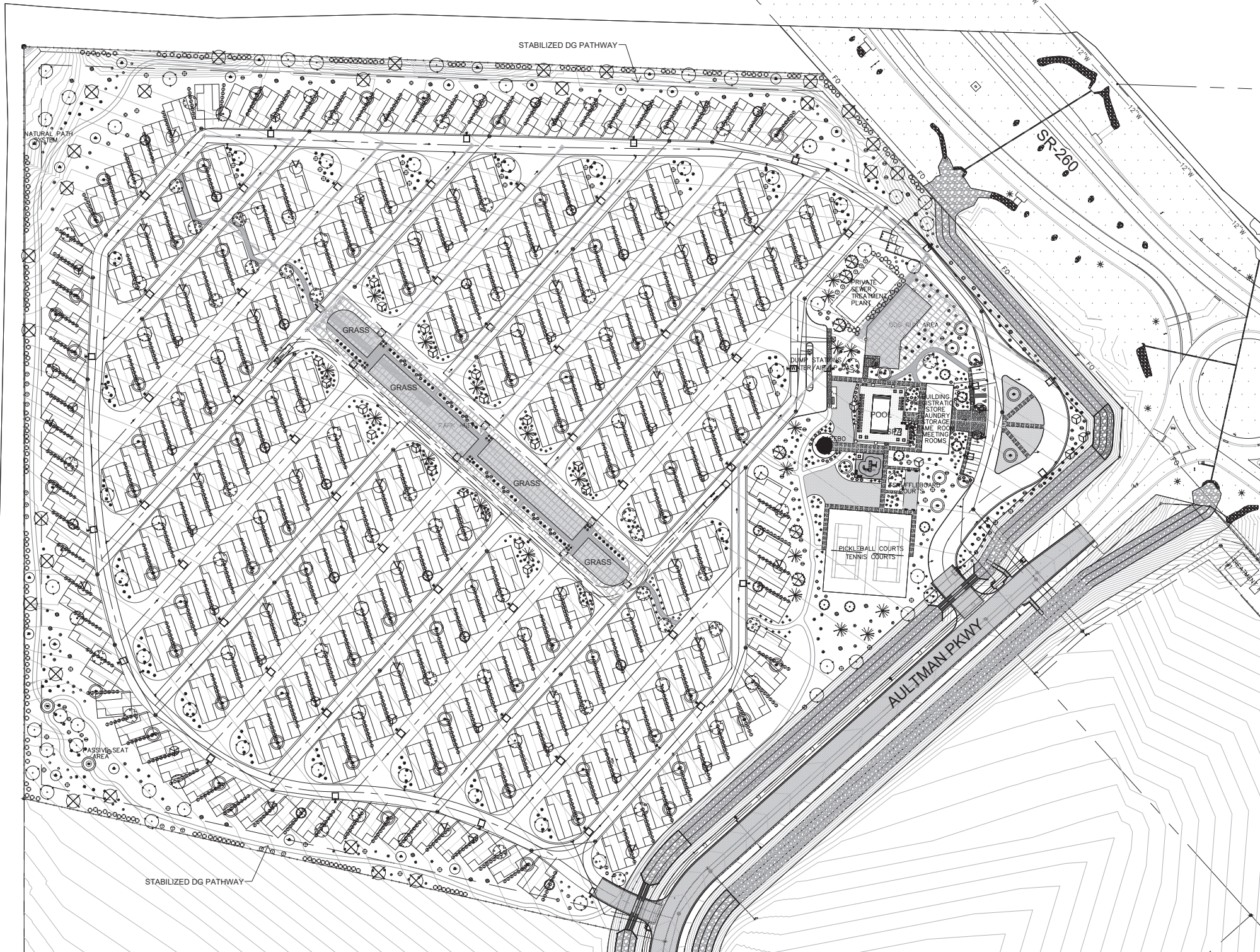

PLANTING PLAN

SCALE: 1"=80'-0"



LANDSCAPE AREA
RV PARK LANDSCAPE AREA: 876,407 S.F.

High View RV Park at Boulder Creek
W. State Route 260, Camp Verde, AZ

12.19.22

Planting Plan

L1.0

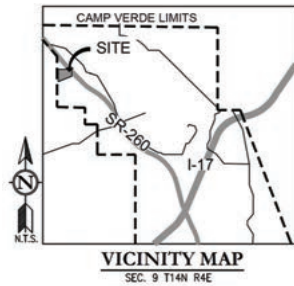
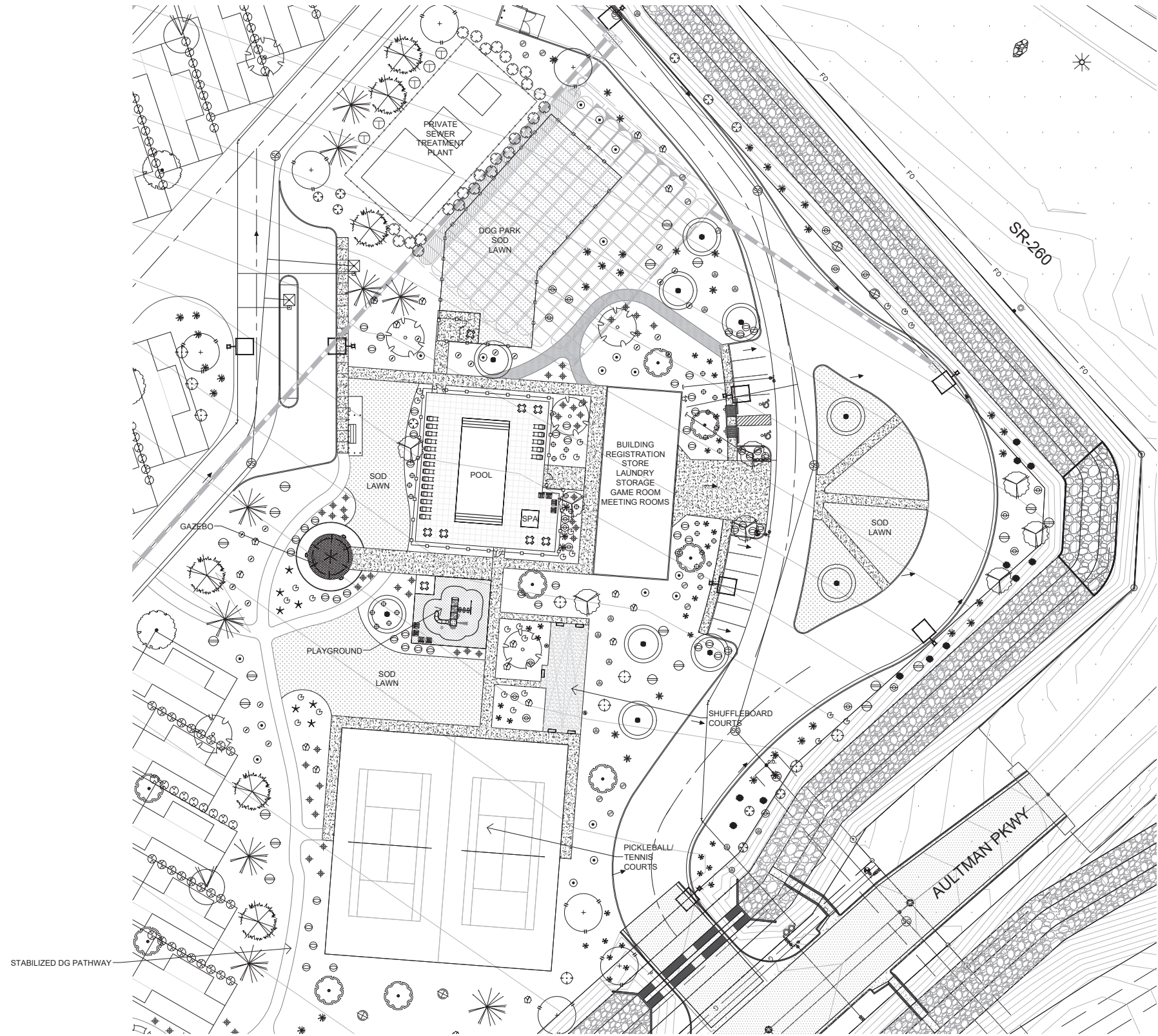

hillman workshop
 landscape architecture
 2901 n. highland ave
 phoenix, az 85016
 480-686-2001



EXPIRES 09/30/25
 03.17.23
 Entry Update

PLANT LEGEND

SYMBOL	BOTANICAL NAME	COMMON NAME	SIZE	QTY	COMMENTS
Deciduous Accent Trees					
	<i>Chilopsis linearis</i> 'Bubba'	Seedless Desert Willow	25 Gal.	28	Multi Trunk, Dense Canopy
	<i>Prunus</i> spp.	Purple Leaf Plum	25 Gal.	51	Multi Trunk, Dense Canopy
	<i>Vitex agnus-castus</i>	Vitex	15 Gal.	22	Multi Trunk, Dense Canopy
Deciduous Shade Trees					
	<i>Fraxinus velutina</i>	Arizona Ash	15 Gal.	11	Standard Trunk, Dense Canopy
	<i>Gleditsia</i> hybrid	Skyline or Shademaster Honey Locust	25 Gal.	30	Multi Trunk, Dense Canopy
	<i>Pistacia chinensis</i>	Chinese Pistache	15 Gal.	80	Standard Trunk, Dense Canopy
	<i>Platanus</i> 'Bloodgood'	'Bloodgood' Sycamore	25 Gal.	58	Standard Trunk, Dense Canopy
	<i>Prosopis velutina</i>	Velvet Mesquite	24" Box	27	Multi Trunk, Dense Canopy
EVERGREEN SHADE TREES					
	<i>Quercus</i> spp.	Oak	25 Gal.	53	Standard Trunk, Dense Canopy
EVERGREEN SCREEN TREES					
	<i>Cedrus deodara</i>	Deodar Cedar	6' B&B	6	Standard Trunk, Dense Canopy
	<i>Cupressus arizonica</i>	Arizona Cypress	25 Gal.	39	Standard Trunk, Dense Canopy
	<i>Pinus eldarica</i>	Afghan Pine	25 Gal.	21	Standard Trunk, Dense Canopy
SHRUBS					
	<i>Anisacanthus thurberi</i>	Desert Honeysuckle	5 Gal.	19	Per Plan
	<i>Caesalpinia gilliesii</i>	Yellow Bird of Paradise	5 Gal.	28	Per Plan
	<i>Calliandra eriophylla</i>	Pink Fairy Duster	5 Gal.	37	Per Plan
	<i>Dalea pulchra</i>	Bush Dalea	5 Gal.	18	Per Plan
	<i>Leucophyllum</i> Species	Sage	1 Gal.	1,962	Per Plan
	<i>Mahonia aquifolium</i>	Oregon Grape	5 Gal.	49	Per Plan
	<i>Photinia x fraseri</i>	Red Tip Photinia	5 Gal.	228	Per Plan
	<i>Rhus trilobata</i>	Three Leaf Sumac	5 Gal.	21	Per Plan
	<i>Salvia greggii</i>	Autumn Sage	5 Gal.	79	Per Plan
	<i>Simmondsia chinensis</i>	Jojoba	5 Gal.	31	Per Plan
	<i>Vauquelinia californica</i>	Arizona Rosewood	5 Gal.	18	Per Plan
GRASSES					
	<i>Aristida purpurea</i>	Purple Three Awn	15 Gal.	70	Per Plan
	<i>Muhlenbergia rigens</i>	Deer Grass	5 Gal.	77	Per Plan
ACCENTS					
	<i>Agave</i> spp.	Agave As Selected	5 Gal.	30	Per Plan
	<i>Dasylirion wheeleri</i>	Desert Spoon	5 Gal.	18	Per Plan
	<i>Hesperaloe parviflora</i>	Red Yucca	5 Gal.	227	Per Plan
	<i>Opuntia violacea</i>	Purple Prickly Pear	5 Gal.	12	Per Plan
	<i>Yucca baccata</i>	Banana Yucca	5 Gal.	7	Per Plan
GROUND COVERS					
	<i>Dalea greggii</i>	Creeping Dalea	1 Gal.	101	Per Plan
	<i>Ericameria laricifolia</i>	Turpentine Bush	1 Gal.	67	Per Plan
	<i>Krascheninnikovia lanata</i>	Winterfat	1 Gal.	12	Per Plan
	<i>Mahonia repens</i>	Creeping Oregon Grape	1 Gal.	16	Per Plan
	<i>Penstemon</i> spp.	Penstemon As Selected	1 Gal.	28	Per Plan
	<i>Rosmarinus 'prostratus'</i>	Creeping Rosemary	1 Gal.	82	Per Plan
MISCELLANEOUS					
	DG	Decomposed Granite - Size: 1/2" Screened Color: 'Mahogany Brown' by RockPro 2" depth in all planting areas (Typ)			
	DG PATH	Stabilized DG Pathway - Size: 1/4" Minus Color: 'Mahogany Brown' by RockPro 2" compacted depth			
	GRASS	Grass- Sod			
	TURF	Turf Playground Soft Fall Surface			

PLANTING ENLARGEMENT

SCALE: 1"=30'-0"

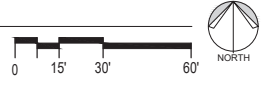

High View RV Park at Boulder Creek
 W. State Route 260, Camp Verde, AZ

DATE: 12.19.22

Planting
 Enlargement

L2.0

PRESCOTT NATIONAL FOREST

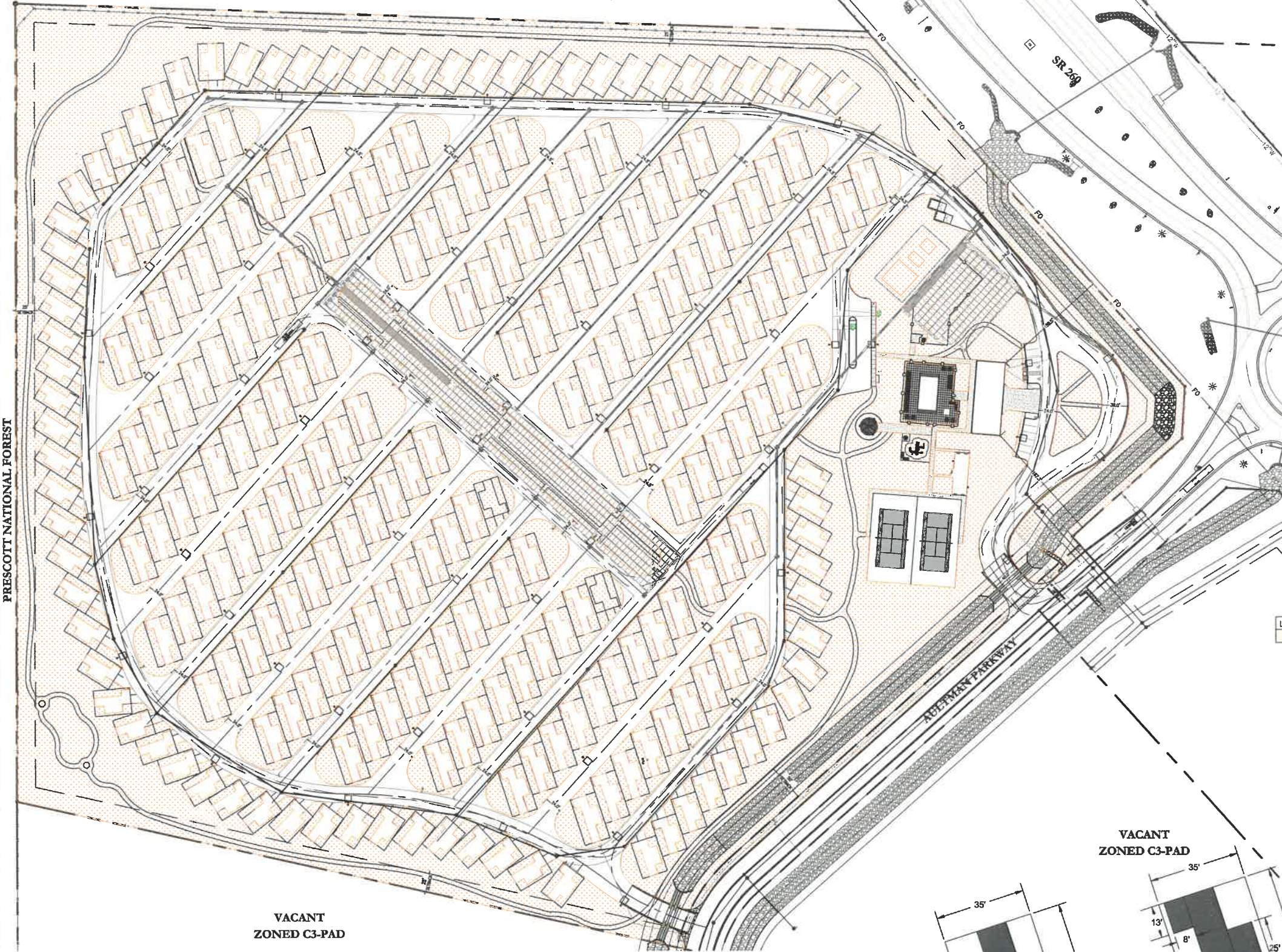

OWNER/DEVELOPER
 ZANE GREY INVESTMENTS II LLC
 661 E. HOWARDS RD
 CAMP VERDE, AZ 86322
 CONTACT: JEREMY BACH
 PH: (928) 300-4440

ENGINEER:
 SBL ENGINEERING, LLC.
 4915 S. DEER TRAIL
 PRESCOTT, AZ 86303
 PH: (480) 290-9630
 CONTACT: CRAIG BAKER
 CRAIG@SBL-ENG.COM

SURVEYOR
 HERITAGE LAND SURVEYING & MAPPING
 PO BOX 3270
 CAMP VERDE, AZ 86322
 PH: (928) 567-9170
 CONTACT: SHANE NAUERT

PARCEL & SITE ADDRESS
 APN# 403-15-003V PARCEL 3
 ADDRESS: ALPERTMAN PARKWAY, CAMP VERDE, AZ
 ZONING: C3-PAD

AREA
 SUBJECT PROPERTY CONTAINS 1,568,596 SQUARE FEET OR 36.01 ACRES.
 DEVELOPED AREA 1,568,596 SQUARE FEET OR 36.01 ACRES.

PROJECT DESCRIPTION
 PROPOSED RV PARK

PROJECT SITE NARRATIVE
 THE RV PARK WILL HAVE A TOTAL OF 248 RV SITES, A 4,000 SQUARE FOOT COMMUNITY BUILDING, 2 TENNIS COURTS, POOL, SPA, SHUFFLE BOARD, DOG PARK, TRAIL SYSTEM, DUMP STATION, LP TANK FILL STATION, PICNIC AREAS AS WELL AS MULTI-USE OPEN SPACE. EACH RV SITE WILL HAVE HOOK UPS FOR SEWER, WATER, ELECTRIC AND WIFI.

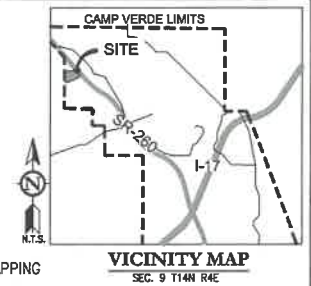

RV SITE TABULATION TABLE		
	SIZE	NUMBER
DRIVE THROUGH SITES	35 X 65	168
END /PERIMETER SITES	35 X 50	78
TOTALS		246
	36.01 ACRES	6.9 / ACRE

LANDSCAPE AREA	876,407 SQ. FT
	56%

VACANT ZONED C3-PAD

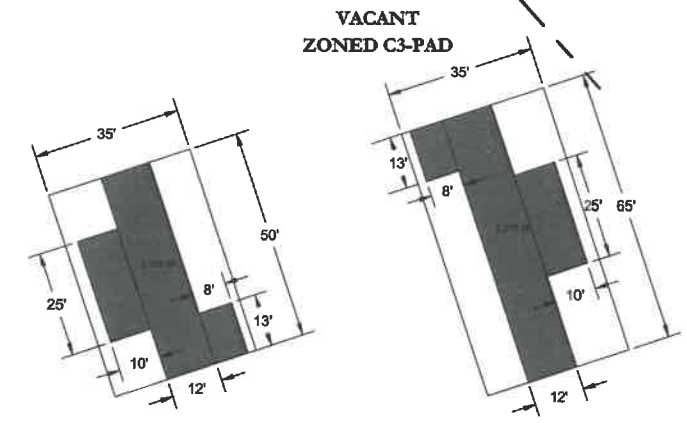

END / PERIMETER SITES (TYPICAL)
 SCALE: 1" = 20'

DRIVE THROUGH SITES (TYPICAL)
 SCALE: 1" = 30'



SCALE: 1" = 70'



**HIGH VIEW RV PARK AT BOULDER CREEK
 W. STATE ROUTE 260, CAMP VERDE, AZ
 OPEN SPACE EXHIBIT**

DATE	
REVISIONS	

DATE: 04/05/23
 PROJ. NO: 21-225
 DESIGN: CB
 DRAWN: JL
 CHECK: JS
 SCALE: 1" = 70'
 CAD FILE: 21225DP

OPEN SPACE EXHIBIT
EX-1
 1 of 1

INFORMATIONAL COPY ONLY UNLESS WITH A VALID PROFESSIONAL SEAL AND SIGNATURE

ATTACHMENT C - Commercial & MF Landscape Plan

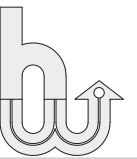
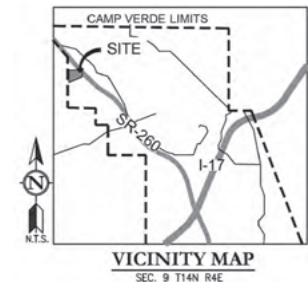

landscape architecture
2901 e. highland ave
phoenix, az 85016
480-686-2001

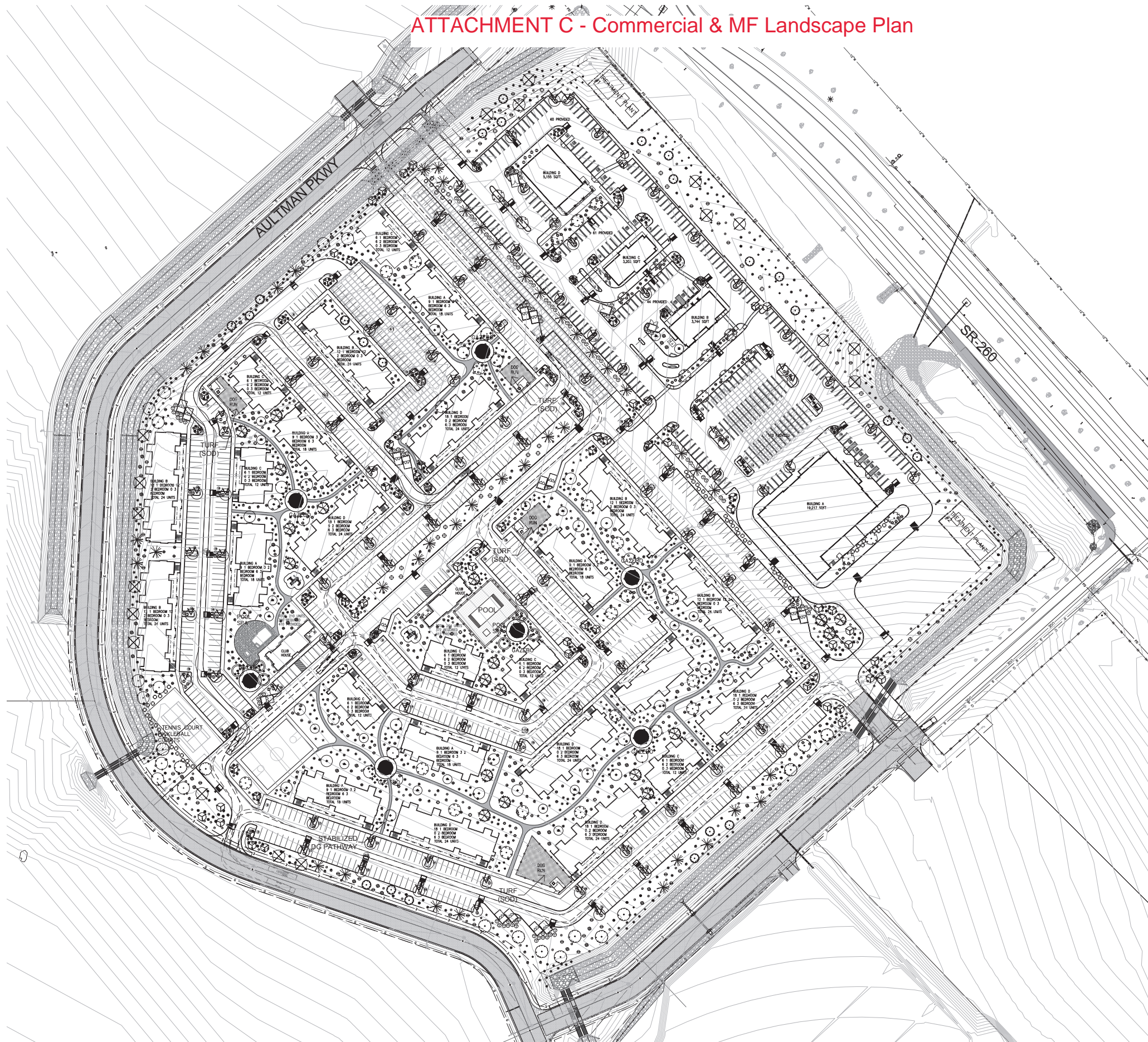

PLANT LEGEND

SYMBOL	BOTANICAL NAME	COMMON NAME	SIZE	QTY	COMMENTS
Deciduous Accent Trees					
	<i>Chilopsis linearis</i> 'Bubba'	Seedless Desert Willow	25 Gal.	24	Multi Trunk, Dense Canopy
	<i>Prunus</i> spp.	Purple Leaf Plum	25 Gal.	96	Multi Trunk, Dense Canopy
	<i>Vitex agnus-castus</i>	Vitex	15 Gal.	23	Multi Trunk, Dense Canopy
Deciduous Shade Trees					
	<i>Fraxinus velutina</i>	Arizona Ash	15 Gal.	23	Standard Trunk, Dense Canopy
	<i>Gleditsia</i> hybrid	Skyline or Shademaker Honey Locust	25 Gal.	98	Multi Trunk, Dense Canopy
	<i>Pistacia chinensis</i>	Chinese Pistache	15 Gal.	6	Standard Trunk, Dense Canopy
	<i>Platanus</i> 'Bloodgood'	'Bloodgood' Sycamore	25 Gal.	27	Standard Trunk, Dense Canopy
	<i>Prosopis velutina</i>	Velvet Mesquite	24" Box	18	Multi Trunk, Dense Canopy
EVERGREEN SHADE TREES					
	<i>Quercus</i> spp.	Oak	25 Gal.	34	Standard Trunk, Dense Canopy
EVERGREEN SCREEN TREES					
	<i>Cedrus deodara</i>	Deodar Cedar	6" B&B	19	Standard Trunk, Dense Canopy
	<i>Cupressus arizonica</i>	Arizona Cypress	25 Gal.	13	Standard Trunk, Dense Canopy
	<i>Pinus eldarica</i>	Afghan Pine	25 Gal.	42	Standard Trunk, Dense Canopy
SHRUBS					
	<i>Anisacanthus thurberi</i>	Desert Honeysuckle	5 Gal.	117	Per Plan
	<i>Caesalpinia gilliesii</i>	Yellow Bird of Paradise	5 Gal.	79	Per Plan
	<i>Calliandra eriophylla</i>	Pink Fairy Duster	5 Gal.	62	Per Plan
	<i>Dalea pulchra</i>	Bush Dalea	5 Gal.	100	Per Plan
	<i>Leucophyllum</i> Species	Sage	1 Gal.	290	Per Plan
	<i>Mahonia aquifolium</i>	Oregon Grape	5 Gal.	25	Per Plan
	<i>Photinia x fraseri</i>	Red Tip Photinia	5 Gal.	69	Per Plan
	<i>Rhus trilobata</i>	Three Leaf Sumac	5 Gal.	33	Per Plan
	<i>Salvia greggii</i>	Autumn Sage	5 Gal.	201	Per Plan
	<i>Simmondsia chinensis</i>	Jobba	5 Gal.	62	Per Plan
	<i>Vauquelinia californica</i>	Arizona Rosewood	5 Gal.	99	Per Plan
GRASSES					
	<i>Aristida purpurea</i>	Purple Three Awn	5 Gal.	128	Per Plan
	<i>Muhlenbergia rigens</i>	Deer Grass	5 Gal.	243	Per Plan
ACCENTS					
	<i>Agave</i> spp.	Agave As Selected	5 Gal.	72	Per Plan
	<i>Dasylirion wheeleri</i>	Desert Spoon	5 Gal.	110	Per Plan
	<i>Hesperaloe parviflora</i>	Red Yucca	5 Gal.	240	Per Plan
	<i>Opuntia violacea</i>	Purple Prickly Pear	5 Gal.	56	Per Plan
	<i>Yucca baccata</i>	Banana Yucca	5 Gal.	84	Per Plan
GROUND COVERS					
	<i>Dalea greggii</i>	Creeping Dalea	1 Gal.	278	Per Plan
	<i>Ericameria laricifolia</i>	Turpentine Bush	1 Gal.	109	Per Plan
	<i>Krascheninikovia lanata</i>	Winterfat	1 Gal.	31	Per Plan
	<i>Mahonia repens</i>	Creeping Oregon Grape	1 Gal.	45	Per Plan
	<i>Penstemon</i> spp.	Penstemon As Selected	1 Gal.	67	Per Plan
	<i>Rosmarinus 'prostratus'</i>	Creeping Rosemary	1 Gal.	60	Per Plan
MISCELLANEOUS					
	DG	Decomposed Granite - Size: 1/2" Screened Color: 'Mahogany Brown' by RockPro			2" depth in all planting areas (1Typ)
	DG PATH	Stabilized DG Pathway - Size: 1/4" Minus Color: 'Mahogany Brown' by RockPro			2" compacted depth
	GRASS	Grass-Sod			
	TURF	Turf Playground Soft Fall Surface			

PLANTING PLAN

SCALE: 1"=80'-0"



LANDSCAPE AREAS
MULTI-FAMILY LANDSCAPE AREA: 498,756 S.F.
COMMERCIAL LANDSCAPE AREA: 203,214 S.F.

High View Multi-Family & Commercial
w. Highway 260, Camp Verde, AZ

02.13.23

Planting Plan

L1.0

1 of 1

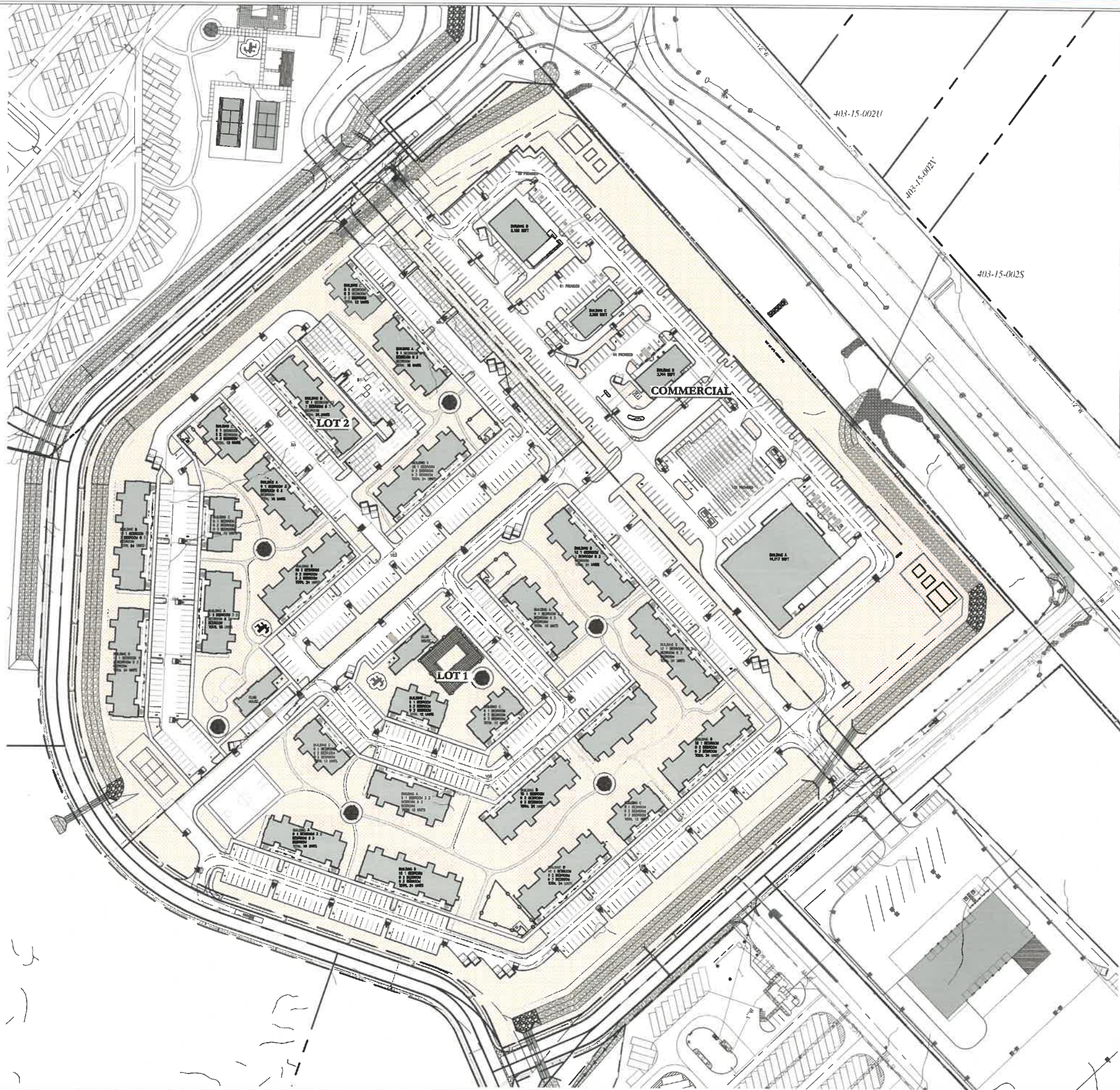

OWNER/DEVELOPER
 JANE GREY INVESTMENTS I LLC
 661 E. HOWARDS RD
 CAMP VERDE, AZ 86322
 CONTACT: JEREMY BACH
 PH: (928) 300-4440

ENGINEER:
 SEL ENGINEERING, LLC
 4915 S. DEER TRAIL
 PRESCOTT, AZ 86303
 PH: (480) 290-9830
 CONTACT: CRAIG BAKER
 CRAIG@SEL-ENG.COM

SURVEYOR
 HERITAGE LAND SURVEYING & MAPPING
 PO BOX 3270
 CAMP VERDE, AZ 86322
 PH: (928) 567-9170
 CONTACT: SHANE NAUERT

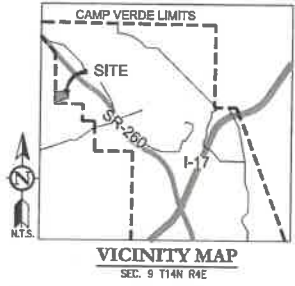

PARCEL & SITE ADDRESS
 APN# 403-15-003J
 ADDRESS: STATE ROUTE 260, CAMP VERDE, AZ
 ZONING: C3-PAD

AREA
 SUBJECT PROPERTY CONTAINS 1,570,774 SQUARE FEET OR 36.06 ACRES.

PROJECT DESCRIPTION
 PROPOSED COMMERCIAL SHOPPING CENTER AND MULTI-FAMILY.

PROJECT SITE NARRATIVE
 THE RV PARK WILL HAVE A TOTAL OF 248 RV SITES, A 4,000 SQUARE FOOT COMMUNITY BUILDING, 2 TENNIS COURTS, POOL, SPA, SHUFFLE BOARD, DOG PARK, TRAIL SYSTEM, DUMP STATION, LP TANK FILL STATION, PICNIC AREAS AS WELL AS MULTI-USE OPEN SPACE. EACH RV SITE WILL HAVE HOOK UPS FOR SEWER, WATER, ELECTRIC AND WIFI.

AREA
 MULTI-FAMILY LOT 1 CONTAINS 642,838 SQUARE FEET OR 14.76 ACRES
 MULTI-FAMILY LOT 2 CONTAINS 499,593 SQUARE FEET OR 11.47 ACRES
 COMMERCIAL LOT CONTAINS 425,875 SQUARE FEET OR 9.78 ACRES

MULTI-FAMILY BUILDING INFO

MULTI-FAMILY LOT 1 CONTAINS	3 BLDG A	3 BLDG B	3 BLDG C	2 BLDG D
	3 BEDROOM UNITS	2 BEDROOM UNITS	EFFICIENCY UNITS	
	117	63	30	

210 TOTAL UNITS
 195 UNITS ALLOWED @ 17 UNITS PER ACRE
 390 PARKING STALLS REQUIRED
 410 PARKING STALLS PROVIDED

MULTI-FAMILY LOT 2 CONTAINS

4 BLDG A	2 BLDG B	4 BLDG C	4 BLDG D
3 BEDROOM UNITS	2 BEDROOM UNITS	EFFICIENCY UNITS	
45	60	156	

264 TOTAL UNITS
 251 UNITS ALLOWED @ 17 UNITS PER ACRE
 372 PARKING STALLS REQUIRED
 412 PARKING STALLS PROVIDED

COMMERCIAL BUILDING INFO

COMMERCIAL LOT CONTAINS	BLDG. A	BLDG. B	BLDG. C	BLDG. D
	19,217 SQFT	3,744 SQFT	3,203 SQFT	5,155 SQFT
PARKING STALLS REQUIRED	97	43	38	58
PARKING STALLS PROVIDED	133	44	61	60

A CROSS ACCESS AND CROSS PARKING AGREEMENT WILL BE IN PLACE FOR THE COMMERCIAL PROPERTY.

BLDG A PROPOSED GROCERY PARKING 1 PER 50 SQFT
 BLDG B & C PROPOSED DRIVE THRU QUICK SERVE RESTAURANT.
 PARKING 1 PER 50 SQFT + 1 PER EMPLOYEE
 BLDG D RETAIL & RESTAURANT 1 PER 50 SQFT + 1 EMPLOYEE/ 1 PER 200 SQFT

LANDSCAPE AREA	MULTI-FAMILY AREA	496,756 SQ. FT	44%
	COMMERCIAL AREA	203,214 SQ. FT	48%

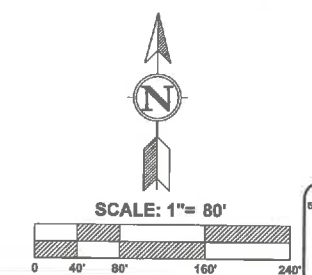

**HIGH VIEW MULTI-FAMILY & COMMERCIAL
 W. HIGHWAY 260, CAMP VERDE, AZ
 OPEN SPACE EXHIBIT**

DATE	
REVISIONS	

DATE: 04/05/23
 PROJ. NO: 22-109
 DESIGN: CB
 DRAWN: JL
 CHECK: JS
 SCALE: 1"=80'
 CAD FILE: 221090PEX

OPEN SPACE EXHIBIT
EX-1
 1 of 1

SECTION 1

AS-BUILD DOCUMENTATION

COMMERCIAL WASTEWATER TREATMENT BIOREACTOR

N1-IM1B-200-901.N

WITH CAPACITY OF 25,017 GPD/ 94.7 M³/DAY



Serial No.:	1361
Order No.:	18-EX-22
Order subject:	Residential and commercial wastewater treatment bioreactor N1-IM2B-225x2-901.N with capacity of 55,000 GPG/ 208 m ³ /day

**SECTION 1
CONTENTS :**

1. AS-BUILT DOCUMENTATION

1	Fig. 1. Dimensions and connections drawing	1.1
2	Fig. 2.Task for foundation design	1.2
3	Fig. 3.Fastening scheme to foundation	1.3
4	Fig. 4 Overall drawing. Vertical cross section. Plan.	1.4
5	Initial data and terms and conditions to apply commercial wastewater treatment system	1.5÷1.8
6.	General information commercial wastewater treatment system	1.9÷1.12

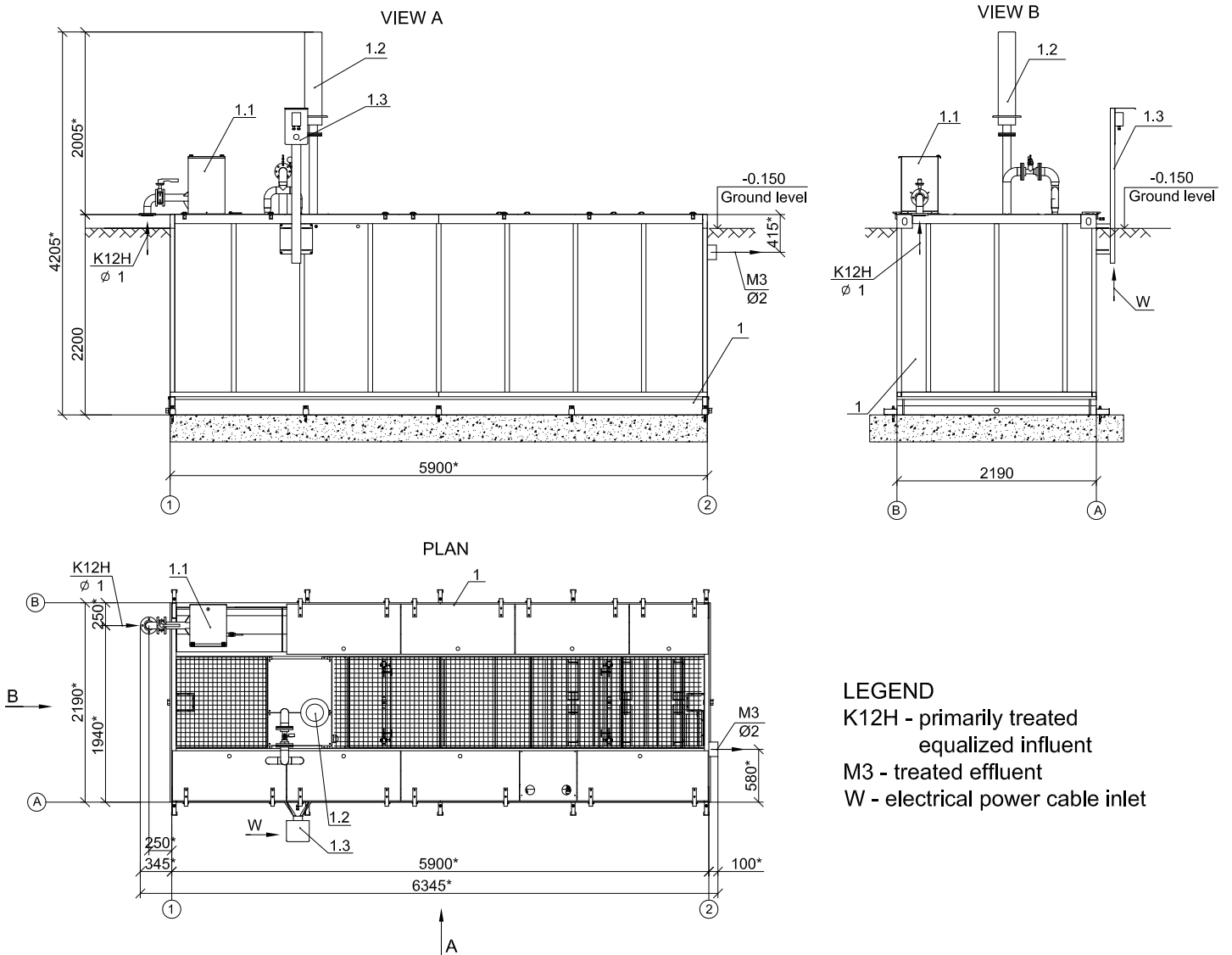

LEGEND
 K12H - primarily treated equalized influent
 M3 - treated effluent
 W - electrical power cable inlet

KEY:

- 1. Multi-chamber bioreactor for biological treatment and nitri-denitrification, including:
 - 1.1 Multifunction inlet chamber
 - 1.2 Submersible compressor
 - 1.3 Electrical panel

CHARACTERISTIC OF PIPELINES

K12H Ø 1	Stainless steel made pipe Ø76.1x2.0 with flange DN-65
M3 Ø 2	Stainless steel made branch pipe Ø 168.3x2.0

NOTE:

* - sizes with tolerance ± 50 mm.

Fig. 1. Dimensions and connections drawing

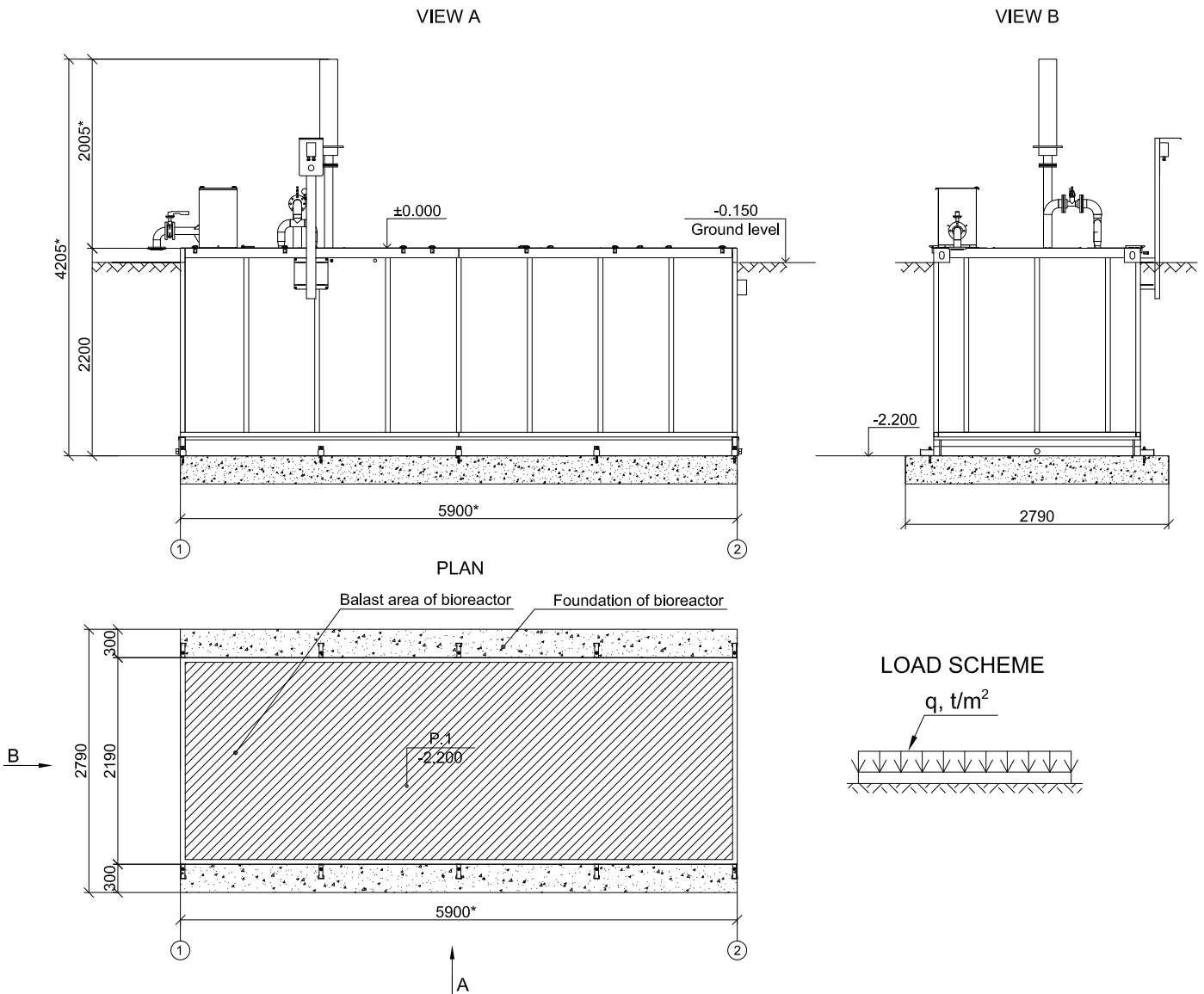

SPECIFICATION OF FOUNDATIONS

Mark	Description	Quantity	Description of equipment loading in working condition, q	Load	
				t	t/m ²
P.1	Plate	1	Multi-chamber bioreactor for biological treatment and nitri-denitrification, q ₁	-	2.5

NOTES:

- Sizes are given in mm, height marks in m.
- Foundation surface should be strictly horizontal with tolerance ± 1 mm.
- Construction, sizes and section compositions are determined by design according to actual initial data, hydro-geological conditions and the indicated loadings.
- After foundation mounting provide slot filling with brought gravel with further tamping and watering.
- * - sizes with tolerance ± 50 mm.
- The load is given for the equipment in working condition without any possible external effecting loads.**

Fig. 2. Task for foundation design

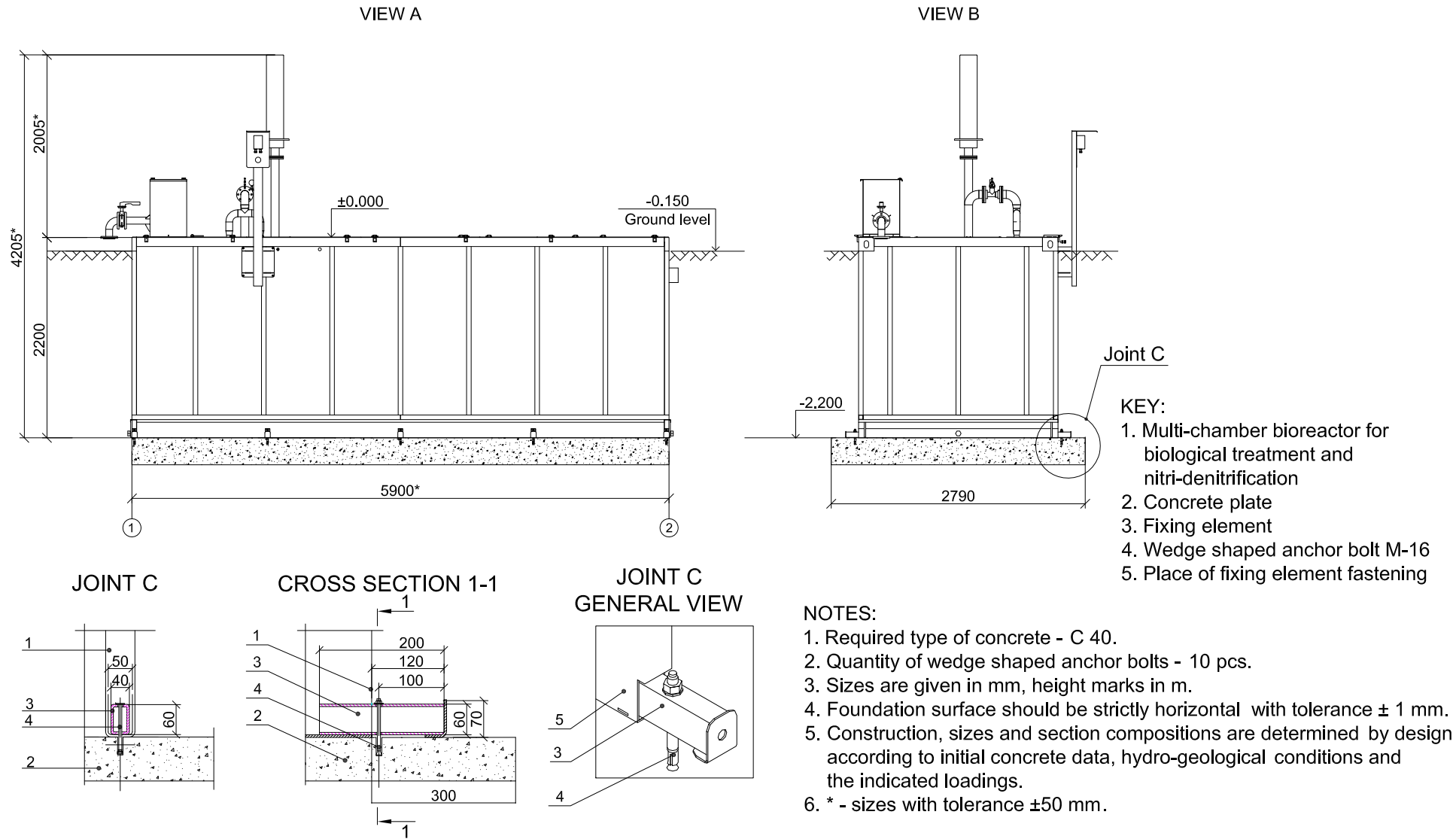
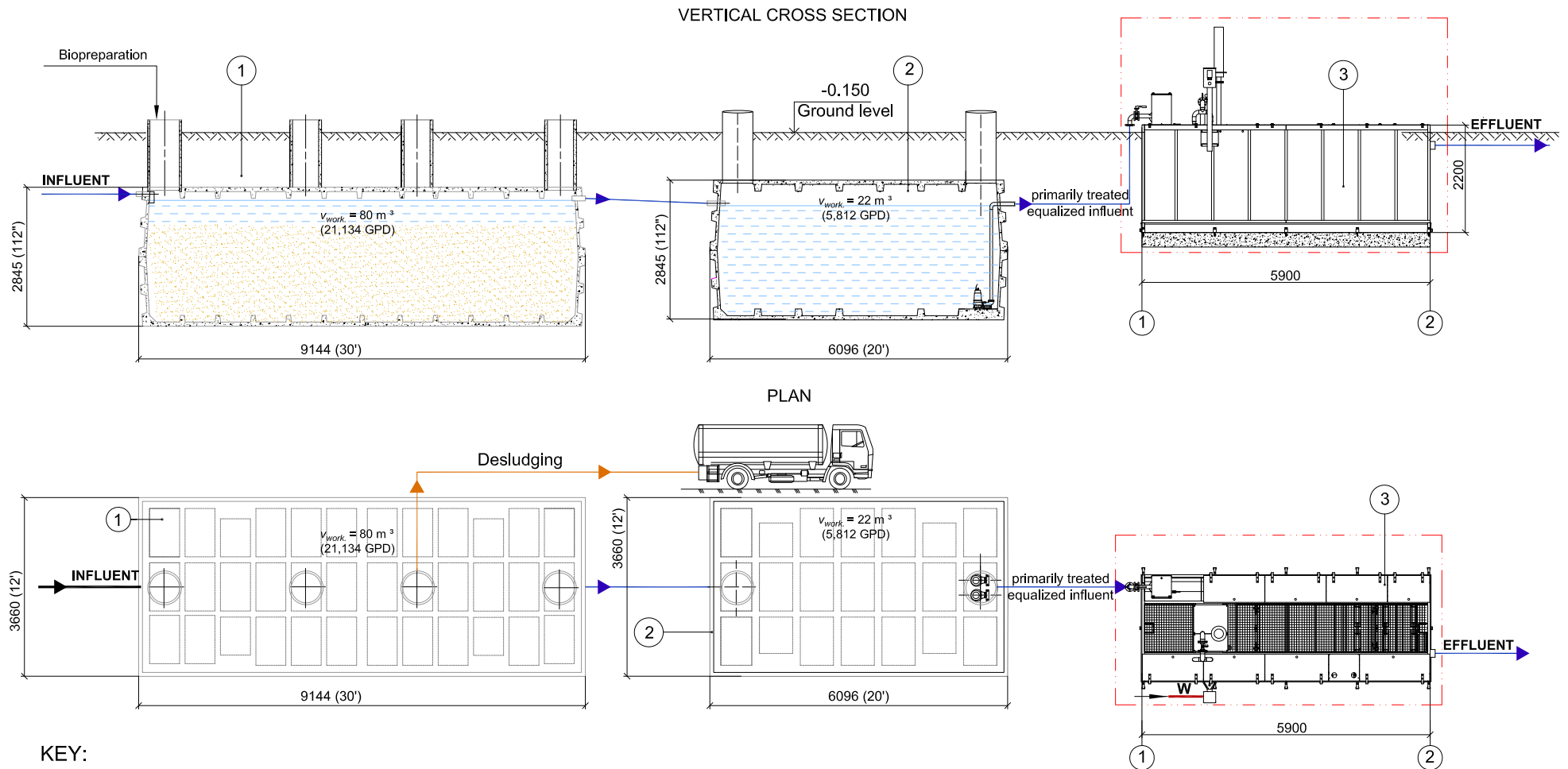

Fig. 3. Fastening scheme to foundation





KEY:

1. Settling-digestion tank
2. Wastewater flowrate equalization tank with equipment for wastewater feeding to Bioreactor
3. Multi-chamber bioreactor for biological treatment and nitri-denitrification

LEGEND

- W - electrical power cable inlet
- Bioreactor's scope of supply

NOTE:

Settling-digestion tank and equalization tank are shown conditionally. Location and dimensions will be precized during engineering design development.

4. Fig. 4. Overall drawing: Vertical cross section. Plan



**1.5 INITIAL DATA AND TERMS AND CONDITIONS TO APPLY
COMMERCIAL WASTEWATER TREATMENT SYSTEM
N1-IM1B-200-901.N**

with capacity up to 25,017 GPD / 94.7 m³/day

I. TREATMENT SYSTEM OVERVIEW

The commercial wastewater treatment system consists of a settling-digestion tank, a flowrate equalization tank followed by a multi-chamber bioreactor for biological treatment and nitrification (hereinafter the Bioreactor).

The settling-digestion tank with the estimated working volume of 21,134 gal (80 m³) should provide wastewater primary treatment: mechanical treatment, including coarse and fine solids and grit removal, FOG (fats, oils and greases) removal, wastewater settling; and formed sludge accumulation and digestion.

The equalization tank with the estimated working volume of 5,812 gal (22 m³) is necessary for wastewater flowrate equalization. The equalization compartment is to be equipped with submersible pumps for dosed wastewater feeding to the Bioreactor for at least 18 hours/day.

The Bioreactor is intended for wastewater biological (secondary) treatment and nitrification.

II. INITIAL DATA

II.1. Wastewater source is commercial. Assumed person equivalent – 1,000.

II.2. Type of wastewater collection and disposal systems:

Type of collection system – gravity collection system.

Type of disposal system – drip disposal system.

II.3. Hydraulic loadings:

Maximal daily (Q_{max}) = 25,017 GPD (94.7 m³/day);

Average hourly ($Q^h_{calc.}$) = 23.16 GPM (5.26 m³/hour).

II.4. Primarily treated and equalized wastewater characteristics:

The primary treatment should ensure that influent characteristics do not affect the performance of the Bioreactor and, in particular, do not inhibit microbiological activity and impede biological treatment process.

The primarily treated wastewater quality should meet the following concentrations:

Suspended solids (SS)	≤ 188 mg/l
5-day Biological oxygen demand (BOD ₅)	≤ 438 mg/l
Total Kjeldahl Nitrogen (TKN)	≤ 80 mg/l
pH	6 to 9 pH units

II.5. Physical and operational parameters:

II.5.1. Assumed outside air temperature: the lowest -10°C, the highest +25°C;

II.5.2. Electrical power on site, i.e. Phases (quantity), Voltage (V), Frequency (Hz):

- Phase - 1, U - 115 V (one leg) and 230 V (two legs), 60 Hz;
- Phase - 3, U - 208 V, 60 Hz;

II.5.3. Elevation above sea level: 3,600 ft (1,098 m).

III. WASTEWATER CHARACTERISTICS TO APPLY BIOLOGICAL TREATMENT PLANT

Stability and efficiency of the biological treatment process with achievement of the required treated effluent quality depend on the raw wastewater characteristics which should comply with values indicated in the below Table:

No.	Quality Indicator	Units	Values		Allowable fluctuations	
			calculated	allowable	daily	hourly
1	2	3	4	5	6	7
1.	Wastewater temperature, T	°C	13÷17	12÷25	± 2°C	±2÷3°C
2.	pH	pH units	7	6.0÷9.0	±0.1÷0.2	±0.3
3.	Hydraulic loading	m ³ /day	100%	5÷100%	-	-
4.	5-day Biological oxygen demand (BOD ₅)	mg/l	625	100÷625	±10%	±20%
5.	Chemical oxygen demand (COD)	mg/l	1167	100÷1167	±10%	±20%
6.	Suspended solids (SS)	mg/l	625	30÷625	±10%	±20%
7.	Total Kjeldahl Nitrogen (TKN) / Total Nitrogen (TN), incl.:	mg/l	80	5÷80	±10%	±20%
	• Nitrates nitrogen (NO ₃ →N)	mg/l	—	—	—	—
	• Ammonium nitrogen (NH ₄ →N)	mg/l	50.0	3÷50.0	±10%	±20%
	• Organic nitrogen (N _{org.})	mg/l	30.0	2÷30.0	±10%	±20%
8.	Total phosphorus (TP)	mg/l	10	1÷10	±10%	±20%
9.	Chlorides (Cl ⁻)	mg/l	50	30÷300	±10%	±20%
10.	Detergents (biodegradable)	mg/l	12.5	2÷12.5	±10%	±20%
11.	Sulphates (SO ₄) ²⁻	mg/l	30	7÷50	±10%	±20%
12.	Alkalinity (CaCO ₃)	mg/l	240	60÷350	±10%	±20%
		mEq/l	4.8	1.2÷7	±10%	±20%
13.	Fats, oils and greases	mg/l	50	7÷50	±10%	±20%
14.	Fecal coliforms	No./100 ml	10 ⁶	10 ⁶ ÷10 ⁸	±10%	±20%
15.	Salinity	mg/l	600	500÷1000	±10%	±20%
16.	Whole effluent toxicity (WET):					
	Acute toxicity	TUc	1.0	—	—	—
	Chronic toxicity	TUa	0.3	—	—	—

The indicated in the above Table allowable deviations of wastewater parameters towards the larger values, caused by daily pollutant load fluctuations not exceeding the calculated values in total, are only acceptable at wastewater temperature not less than +12°C.

IV. TERMS AND CONDITIONS TO APPLY BIOLOGICAL TREATMENT

IV.1. Terms and conditions for normal operation of biological treatment process:

- For normal regeneration of biocenoses the optimal nutrients ratio content should correspond to the ratio **BOD_{tot} : N : P = 100 : 5 : 1**.
- The normal biological treatment process is achieved by maintaining in wastewater the ratio value of **BOD_{tot} / COD ≥ 0,75**.
- The wastewater salt content entering biological treatment step should not be higher than 0,5 g/l.
- Ash content in primary sludge should not be higher than 35%.

- The performance of the Plant is based on the condition that no inhibiting, harmful or toxic components are present in concentrations which inhibit or stop biological activity and microorganisms growth.

IV.2. Sludge-digestion tank operation:

- Sludge-digestion tank should be operated with constant application of the biopreparation *Bacti-Bio 9500*. This biopreparation provides high effect to stabilization ensuring effective primary management, significant reduction of primary sludge volume and odour prevention.
- Sludge level should be constantly monitored by means of automatic sludge level sensor or manual Sludge Judge device.
- Routine desludging is to be done as frequently as needed to avoid sludge overflow into the Bioreactor which is strictly forbidden.

IV.3. Guidelines for FOG handling:

- FOG level should be constantly monitored. If influent FOG concentration is permanently higher than 50 mg/l in any of local discharges, then it is necessary to apply constantly specially selected biopreparation for FOG decomposition. If influent FOG concentration exceeds 100 mg/l, then it is necessary to build a local grease trap and use in it the biopreparation for FOG decomposition.

IV.4. Guidelines for commercial or industrial operation:

- Every building, structure, or premises used or occupied by any sewer user where any commercial or industrial operations are conducted or permitted which result in the discharge into the sewer system of any products, waste products, or other substances, matter, or liquid in the manner and to the extent prohibited in this section shall be equipped with an adequate and suitable grease trap, filter, or other interception device installed in such a manner that the product, waste products, or other substances, materials, or liquid herein set forth will not flow into or be discharged into the sanitary sewer system.

V. PROHIBITED DISCHARGES

V.1. General

- The biological treatment process is very stable. However inhibitors may adversely impact the effluent quality from the biological treatment system. Therefore, none of the following biologically non-degradable or hard-to-degrade substances or wastewaters should be introduced into the sanitary sewer system:
 - Cooking oil or melted fat e.g. from grill tray or chip pan;
 - Water or waste having pH higher than 7.5 or lower than 6.5;
 - Blood;
 - External cleaning agents and disinfectants (household cleaners);
 - Salt or salty water/solutions;
 - Regeneration water from drinking/process water treatment equipment;
 - Stormwater from roofs and impervious surfaces;
 - Water from swimming pools after their refill or scheduled maintenance;
 - Excrements of animals;
 - Faecal water/sludges;
 - Any medical wastes, except as specifically authorized by the administrative authority;
 - Any detergents, surface-active agents, or other substances in amounts which may cause excessive foaming and or treatment process inhibition.
- No user shall introduce or cause to be introduced into the sanitary sewer any pollutant or wastewater which causes pass through or interference:

The substances and materials which have ability to clog pipelines, wells, bar racks or leave deposits inside pipelines: sanitary towels, tampons, cotton wool, incontinence pads, etc.,

garbage which has not been properly shredded, municipal solid wastes, floating up wastes, insoluble fats, oils, tars, petroleum oil, etc., biologically hard surface active agents (surfactants), rubber gloves, gauze pads, bakers clothing (coats, hats, aprons etc.), mill scale, lime, grit, gypsum, swarf, paunch manure, ground, construction wastes and trash, solid or viscous substances in quantities restricting pipeline flow or other interference with the proper operation of sewage and pipes.

V.2. Specific prohibitions:

- Any pollutant which either alone or by interaction may create a fire or explosive hazard in the sanitary sewer;
- Substances which have a devastating effect on the material pipelines, equipment and other facilities of sewerage systems: acids, solvents, alkali, etc.

This list cannot be totally comprehensive or exhaustive - just be careful and cautious before discarding any substances, materials or chemicals into the sanitary sewer system.

 If subsequent operation will show that actual wastewater flows and loads, as well as any other conditions differ from the described in the present document, the Bioreactor and/or the entire System should be resized and/or optimized from point of dimensional characteristics, process and technology. In such case the Manufacturer and its local Distributor are not responsible for treated effluent quality and withdraw from any guarantees.

VI.TREATED EFFLUENT QUALITY

Treated effluent quality meets the following requirements:

Suspended solids (SS)	≤ 10 mg/l
5-day Carbonaceous biological oxygen demand (CBOD ₅)	≤ 10 mg/l
Total Nitrogen (TN)	≤ 10 mg/l
pH	6 to 9 pH units

 The Manufacturer of the Bioreactor guaranties the indicated treated effluent quality under the following conditions:

- Raw and primarily treated wastewater quality should correspond to the subject terms and conditions;
- The System’s Owner should ensure normal System operation and maintenance in accordance with the Manufacturer’s requirements.

1.6 GENERAL INFORMATION COMMERCIAL WASTEWATER TREATMENT SYSTEM

N1-IM1B-200-901.N

with capacity up to 25,017 GPD / 94.7 m³/day

I. APPLICATION

The commercial wastewater treatment Bioreactor is intended for wastewater biological (secondary) treatment and nitri-denitrification (hereinafter the Bioreactor).

The Bioreactor application should be in compliance with the Initial data which it has been sized for and the specified Terms and Conditions.

II. SCOPE OF SUPPLY

- bioreactor for wastewater biological (secondary) treatment and nitri-denitrification with multifunctional inlet chamber.

III. EQUIPMENT SPECIFICATION

III.1. MULTIFUNCTIONAL INLET CHAMBER

Function:

The multifunctional inlet chamber (hereinafter the Chamber) insures:

- wastewater receiving to the Bioreactor,
- flow stilling,
- flow volumetric measurement,
- sampling and measurements,
- assessment of wastewater quality (color, smell, density).

If necessary, it is used as a mixing place to introduce:

- biopreparation.

Construction:

The Chamber is a rectangular, vertical tank, stainless steel made AISI 304.

Equipment:

The Chamber is equipped with:

- supply pipeline,
- internal drain riser,
- drainage pipeline with tap,
- lid.

III.2. BIOREACTOR FOR BIOLOGICAL TREATMENT AND NITRI-DENITRIFICATION

Function:

- advanced biological treatment, incl. nitri-denitrification, in the multi-chamber aeration tank (nitri-denitrification tank).

Construction:

The Bioreactor is a rectangular tank, stainless steel made AISI 304 divided with baffles in three chambers.

Equipment:

The 1st chamber is equipped with:

- fine-bubble aerators for saturation with oxygen,
- medium-bubble aerator for floating media mixing,
- floating media,

- submersible compressor.

The 2nd chamber is equipped with:

- fine-bubble aerators for saturation with oxygen,
- medium-bubble aerator for floating media mixing,
- floating media.

The 3rd chamber is equipped with:

- fine-bubble aerators for saturation with oxygen,
- block static media,
- control tubes with mounting brackets.

There are provided special constructive elements, i.e. stainless steel mesh and limiter, to prevent floating media overflow from the first chamber to the second and from the second chamber to the third one.

For the Bioreactor draining and servicing maintenance shafts are provided in the 1st and the 3rd chambers. The draining can be carried out by a service pump.

The shaft in the Bioreactor's 1st chamber with floating media represents a stainless steel made standpipe welded on the sidewall of the chamber. When the chamber is filled with floating media, openings in the shaft bottom are closed with stainless steel mesh in order to prevent floating media inflow into the shaft.

The maintenance shaft in the Bioreactor's 3rd chamber with block media is made by cut-out in the media.

Air supply in the Bioreactor is provided by a submersible compressor. Air feeding pipelines are supplied to distribute air within the whole Bioreactor.

The Bioreactor is equipped with air distribution pipelines, necessary fittings and fixing elements.

The Bioreactor is partially covered with stainless steel made lids.

Electrical power supply and control

The Bioreactor is equipped with the electrical panel. Power supply cable is to be connected to the electrical panel.

IV. PROCESS DESCRIPTION

IV.1. GENERAL PROVISIONS

The wastewater is treated in two steps:

- primary treatment with the following hydraulic equalization,
- secondary treatment – biological treatment and nitri-denitrification.

IV.2. PRIMARY TREATMENT

First, wastewater flows to the settling-digestion tank where primary treatment takes place: coarse and fine solids and grit removal, FOG (fats, oils and greases) removal, wastewater settling as well as formed sludge accumulation and digestion applying the special biopreparation.

The sludge level should be constantly monitored and the settling-digestion tank routine desludging is to be done as frequently as needed to avoid sludge overflow into the Bioreactor which is strictly forbidden.

IV.3. FLOWRATE EQUALIZATION AND WASTEWATER FEEDING TO PLANT

After the primary treatment wastewater comes by gravity to the equalization tank, where wastewater flow equalization takes place. The equalization tank is equipped with submersible pumps for wastewater feeding to the Bioreactor.

The required wastewater feeding duration to the Bioreactor is at least 18 hours/day.

The calculated feeding volume is:

$$v = Q_{\text{day}} / 18, \text{ m}^3/\text{hour},$$

where Q_{day} is wastewater amount per day.

IV.4. MULTIFUNCTIONAL INLET CHAMBER

Wastewater under pressure enters the Chamber at some distance from its bottom. The feed stream hits the riser, is cut into two parts and flows around it. Thus, pressure is extinguished and powerful turbulence is created. The water level in the tank rises. Upon reaching the head of the riser, wastewater is drained through the riser into the Bioreactor. The drain allows the Chamber to be emptied when the feeding is off.

IV.5. BIOLOGICAL TREATMENT

General process characteristic

The biological process is based on biofilm technology. Biofilm is a dense community of attached-growth microorganisms living on specially designed plastic carriers (media). Having direct contact with wastewater, biofilm absorbs and oxidizes pollutants thus providing treatment. Multiple biozones ensure that an appropriate biological system develops according to the nature of wastewater composition. It supports dynamic balance on its own both in mass and qualitative composition according to variations of wastewater parameters (within the range of optimal adaptation rates and permissible values of calculated loads). Due to efficient ecosystem development in the bioreactor there is *no excess biomass growth*.

The process configuration creates conditions for simultaneous nitri-denitrification without need of recycle.

Process description

The Bioreactor consists of three flow-type chambers.

1st chamber - hydrolysis-fermentation

Function:

- oxidation of main part of organic matter 60÷70%.

Processes:

- sorption and oxidation of dissolved organic matter (BOD) by biofilm;
- hydrolysis of colloids and suspended solids (SS) by exoenzymes secreted by biofilm microorganisms;
- sorption and oxidation of hydrolysis products.

2nd chamber - hetero-autotrophic nitri-denitrification

Function:

- oxidation of hydrolysis residues of organic matter;
- nitri-denitrification of ammonium nitrogen (oxidation - reduction);
- trophic mineralization of biomass overgrowth;
- biological disinfection.

Processes:

- oxidation of organic matter;
- low organic loading maintenance of the optimal level of calculated dissolved oxygen (DO) allows the formation and existence of layered biofilm in the body of floating media. The media is flat disks, each ~1 mm thick, with high pass-through porosity. On the outer sides of the disk 0.25÷0.35 mm thick aerobic biofilm functions. On the inner sides of the disk 0.5÷0.3 mm thick anaerobic biofilm functions.

In the outer sides of the disks, organic matter are oxidized and heterotrophic nitri-denitrification occurs.

In the inner part of the discs, autotrophic nitri-denitrification takes place carried out by *ANAMMOX* bacteria;

- a significant amount of the attached protozoa such as ciliates-peritrichs (filterers) effectively mineralize biomass (BM), thereby clarifying and disinfecting wastewater.

3rd chamber - polishing

Function:

- oxidation of organic matter residues (BOD and SS);
- fine post-treatment of ammonium nitrogen residues (nitrification);
- trophic mineralization of biomass overgrowth;
- biological disinfection.

Processes:

- biofilm carries out sorption and oxidation of BOD residues;
- low organic loading on biofilm promotes the release of exopolymers by bacteria;
- the exopolymers ensure suspended solids (SS) and biomass residues adsorption on biofilm surface;
- grazing microorganisms feed on the adsorbed biomass thereby carrying out trophic mineralization and disinfection;
- low organic load and high dissolved oxygen (DO) level contribute to the fine treatment of ammonium nitrogen residues.

Oxygen conditions

Oxygen supply and mixing are provided by aeration.

The oxygen mode is a function of the following factors:

- organic load,
- thickness and density of biofilm,
- wastewater temperature.

The required amount of dissolved oxygen for each process stage should be optimized and adjusted according to the User manual recommendations.

Start-up and commissioning

Formation of the biofilm occurs spontaneously, without operation staff interference, based on set and maintained level of dissolved oxygen in each chamber. After a period of successions, the dynamic equilibrium is reached, which is characterized by stable treatment process performance in accordance with the project requirements.

At the beginning, the maturation of the first biocenoses (pioneer communities of attached-growth microorganisms) occurs, which form the base to secure working biocenosis formation later. This stage takes 3 ÷ 5 days.

At the next stage, the working heterotrophic biocenosis forms. The formation occurs after several successions. This stage takes 7 ÷ 20 days.

Simultaneously but for a longer time, maturation of a more complex heterotrophic biocenosis occurs. It takes 7 ÷ 40 days. This biocenosis contains microorganisms which provide organics oxidation with simultaneous heterotrophic nitri-denitrification.

For the last biocenosis maturation stage the special conditions should be created to initiate development of slowly growing *ANAMMOX* bacteria, which gradually, as they grow, displace and finally replace the heterotrophic bacterial biocenosis. This stage can take 21 ÷ 350 days.

V. UTILITY CONSUMPTIONS

- Power consumption (all the equipment within the Bioreactor's scope of supply) – 40,953.00 kW·h/year.



Agenda Item Submission Form – Section I

Meeting Date: Planning and Zoning Commission: Thursday, April 13, 2023

Consent Agenda Decision Agenda Executive Session Requested

Presentation Only Action/Presentation Pre-Session Agenda

Requesting Department: Community Development

Staff Resource/Contact Person: John Knight, Community Development Director

Agenda Title: Discussion, consideration and possible recommendation to the Mayor and Common Council of the Town of Camp Verde, Yavapai County, Arizona for approval of an Agritourism Use Permit Application for Trampus and Bonnie Mansker for a private roping arena located at 2083 E Hardy Lane (parcels 404-12-422D and 404-12-422C).

List Attached Documents:

- A. Letter of Intent from Applicant
- B. Site Plan
- C. Application with Affidavit of Neighborhood Meeting
- D. Petition and Letters of Support
- E. Relevant Zoning Ordinance Sections
- F. Current GIS
- G. Conditions of Approval
- H. Other Use Permits

Estimated Presentation Time: 10 minutes

Estimated Discussion Time: 10 minutes

Executive Summary: Trampus Mansker has applied for an Agritourism Use Permit so that he may increase his animal count numbers for a private roping arena. The property is zone R-R (Residential-Rural, 2-acre minimum lot size). The applicant would like to use his arena to allow the youth of Camp Verde, as well as adults, to have somewhere safe and free to practice roping skills and prepare for rodeo competitions. He also proposes to host the Camp Verde 4-H and Camp Verde FFA livestock workshops. In addition, Mr. Mansker proposes to offer free horseshoeing and horsemanship clinics to the youth of Camp Verde and surrounding areas. An Agritourism permit is a conditionally permitted use in the R-R zoning district.

Subject Parcels: APN 404-12-422D and
404-12-422C



Background Information: The Mansker family moved to Camp Verde in 2021 when they purchased 4.69 acres located on Hardy Lane. They purchased these parcels of land so that they would have enough property for their children to practice their roping and barrel racing events, as well as raise animals.

According to the applicant: *“We have decided to apply for the Agri-Tourism permit to allow us to focus on agriculture and western heritage for the youth and people of the Verde Valley. We feel that agriculture and western heritage impact the youth in a very positive way. We believe that in today’s culture it is a valuable lifestyle that we should provide for the youth, or it will continue to diminish and what we once knew and cared so deeply for will only be a memory. Our goal is to provide a safe environment for members of the community to ride horses, team rope, barrel race, and participate in other western events free of charge.”*

As a result of the applicant's use of the arena and the keeping of animals, there was a code complaint sent to the Town in June of 2021. The complaints were primarily related to the number of animals and the concerns about odor and flies. The applicant was routinely exceeding the maximum number of large animals allowed on the property. On the 4.69 acre property, a maximum of nine (9) large animals are allowed.

In an effort to provide a compromise solution, former Community Development Director Melinda Lee informed Mr. Mansker that that he could exceed the animal count during the day, provided there were no more than nine (9) animals on the property at night. Ms. Lee also recommended that he pursue an Agritourism Use Permit as a more permanent solution.

The applicant did not pursue an Agritourism permit in 2021 and the complaints from the neighbor continued. The applicant approached the town with an alternate solution that would allow him to use his neighbor's, adjacent properties for the keeping of animals. This was discussed with the former attorney, Bill Sims and former Town Manager, Russ Martin. It was determined that this would be allowed, provided the applicant had a legal instrument, such as a lease, with his neighbors.

At that time, Mr. Mansker got permission (via letters) from his neighbors to move the cattle to their property when they were not roping. This approach was in keeping with the direction provided by the Town at that time. However, a legal instrument, such as a lease, was never pursued. The Town continued to receive complaints from the neighbor. After consultation with legal staff and follow-up with the applicant, the Town highly encouraged Mr. Mansker to pursue an Agritourism Permit.

In the meantime, Mr. Mansker has diligently worked to mitigate any nuisance that may be associated with keeping animals on his property. He has purchased a dump trailer that he loads his manure in daily and hauls to the Grey Wolf Dump when the trailer is full, at least once a week.

As part of the application submittal, Mr. Mansker has voluntarily proposed a variety of mitigation measures to address nuisance concerns (see Letter of Intent, Attachment A). A summary is included below.

- Manure will be picked up daily (weather permitting), contained in dump trailer and hauled off property a minimum of 1 time weekly.
- Fly traps will be hung around all livestock pens to help control flies.
- Arena will be watered before every event to control dust.
- No outdoor lighting will be installed at the arena.
- All parking will be on-site. No one will park on the street.
- There will be no amplified speaker systems.
- There will never be more than two (2) overnight guests and they will be limited to ten (10) days, which follows the Town Code.
- The property landscape will always be properly maintained.
- No more than 35 large animals will be on the property overnight.

Discussion: In addition to a definition, there are two sections with our current Planning and Zoning Ordinance which regulate Agritourism Use Permits. These are discussed below.

1. Section 103, Definition of Terms:

AGRITOURISM: *Is the act of visiting a working farm, ranch, agricultural or horticultural agribusiness operation for the purpose of enjoyment, education or active involvement of visitors to experience a rural lifestyle. Visitors may participate in events and services related to agriculture which may take place on or off the farm or ranch, and that connect consumers*

with the heritage, natural resource or culinary experience they value. This may include but not limited to; farm stands or shops, U-pick, on-farm classes, fairs, festivals, pumpkin patches, wineries, barn dances, corn maze, hunting, fishing, guest ranches, agricultural tours, wildlife viewing or bird watching, wine tasting.

Staff Response: The applicant's proposed use of the property for FFA/4-H Meetings, farrier workshops, roping/barrel racing clinics and horsemanship workshops appears to be in keeping with this definition. Note that the definition specifically mentions visiting a ranch for "...enjoyment, education or active involvement to experience a rural lifestyle".

2. Section 203.D.3.e.f. – R-R District (Conditional Uses)

Agri-Tourism, Application submission, required information, procedures and review are subject to Use Permit and criteria and specific showings of:

- 1) *Adequate points of direct ingress and egress for patron safety and direct emergency vehicle access;*
- 2) *Ample on-site parking for normal business activity and provisions for special event overflow parking;*
- 3) *Adequate separation distance limitation of hours of operation, and/or additional measures to mitigate negative effects of lighting, noise, traffic, dust and other detrimental environmental factors on nearby residential uses or vacant residentially zoned property.*
- 4) *Provision for patrons' health, safety and comfort including but not limited to shade, first aid and water stations, sanitary facilities, food and beverages, trash receptacles/removal, and appropriate security.*

Staff Response: Through approval of the recommended conditions, it appears that these criteria can be met. Specifically:

- 1) Ingress/egress – ingress and egress will be provided via a public street and will be sufficient for emergency access.
 - 2) On-site parking – the property is over four (4) acres in size and can easily accommodate on-site parking for visitors. Staff has included a condition that requires all parking to be provided on-site.
 - 3) Mitigation Measures – a variety of mitigation measures are included in the conditions to address possible impacts related to noise, lights, dust, odor, hours of activities, etc.
 - 4) Health/Safety – most of the events will be relatively small, however, for larger events (up to 60 people), a condition is included that requires shade, first-aid, water, etc.
3. Section 601 – Zoning Decisions, specifically 601.C provides the guidance on the application and approval process for all Use Permits (see attachment E).

1. Review and Approval

- a. *Use Permits will be granted only upon a finding by the Council that the use covered by the permit, the manner of its conduct, and any structure which is involved, will not be detrimental to persons residing or working in the vicinity, to adjacent property, to the neighborhood, or to the public welfare in general, and that the use will be in conformity with any conditions, requirements, or standards prescribed by the Town Code or Council.*
- b. *Use Permits may contain specific limitations on the scope, nature and duration of the use, as deemed proper in accordance with the following criteria:*
 - 1) *Any significant increase in vehicular or pedestrian traffic;*
 - 2) *Nuisance arising from the emission of odor, dust, gas, noise, vibration, smoke, heat, or glare at a level exceeding that of ambient conditions;*
 - 3) *Contribution to the deterioration of the neighborhood or to the downgrading of property values which, is in conflict with goals, objectives or policies of the General Plan;*
 - 4) *Compatibility with existing surrounding structures and uses; and*
 - 5) *Adequate control of disruptive behavior both inside or outside the premises, which may create a nuisance to the surrounding area or general public.*
- c. *The burden of proof for satisfying the above requirements shall rest with the applicant. A refusal of a Use Permit shall not be interpreted as the denial of right, conditional or otherwise.*
- d. *Where an application involves a definite development scheme, the applicant must submit a layout and landscape plan, building elevations and other pertinent data as may be requested, and the Council may condition the Use Permit to fully carry out the provisions and intent of the Zoning Ordinance.*
- e. *The Use Permit is valid and operable only for the specific use as granted and subject to any specified time limit. No use may be modified, changed, altered or increased in intensity, in any manner that conflicts with the Use Permit and/or required conditions of approval, without approval of a new Use Permit.*

Staff Response: The key criteria referenced above allows for conditions to ensure the proposed use, “...will not be detrimental to persons residing or working in the vicinity, to adjacent property, to the neighborhood, or to the public welfare in general...” Staff’s opinion is that the approval of this use permit with the proposed conditions, will ensure compliance with this key criteria and other provisions of this section.

Other Use Permits: The Town has approved several other agritourism permits over the years. A brief summary of these is included in Attachment H. For reference, staff has also included a copy of the resolution for the Jackpot Ranch CUP.

The following have been completed by staff:

- Neighborhood meeting was held by applicant on November 17, 2022; several community members attended.
- The Town mailed letter providing notice of this public hearing and proposed Use Permit to all parcel within 300’ of this parcel on March 16, 2023.
- A public hearing notice was placed in the Verde Independent Newspaper on March 22, 2023, and March 26, 2023.
- A public hearing notice was posted at the property on March 29, 2023.
- A meeting agenda was posed at Town Hall and Bashas’ on April 6, 2023.

Recommended Action (Motion): Motion to recommend to the Mayor and Common Council of the Town of Camp Verde, Yavapai County, Arizona for approval of an Agritourism Use Permit Application for Trampus and Bonnie Mansker for a roping arena located at 2083 E Hardy Lane (parcels 404-12-422D and 404-12-422C).

The motion also includes approval of the Applicant's Letter of Intent (Attachment A), Site Plan (Attachment B), and additional conditions recommended by staff included in Attachment G (which may be modified by the Commission).

ATTACHMENT A

February 27, 2023

Trampus and Bonnie Mansker

2083 E Hardy Lane

Camp Verde, Arizona 8322

RE: Agritourism Use Permit

To Whom It May Concern:

We are applying for an Agritourism Use Permit for our parcels (APN 404-12-422C and 404-12-422D), located at 2083 E Hardy Lane.

We feel that agriculture and our western heritage are an important focus for the youth, as well as adults, in the Town of Camp Verde and the Verde Valley. We believe that in today's culture, it is a valuable lifestyle and we should be stewards of that lifestyle, or it will continue to diminish from our society. Our goal is to provide a safe environment for members of the community to ride horses, team rope, barrel race, prepare for the Verde Valley Fair, and participate in other western events free of charge.

We are looking to hold several types of free events on our property that pertain to agriculture and the western heritage that is included in the Town of Camp Verde's General Plan. Some of these events include, but our not limited to:

- FFA Club Meetings
- 4-H Club Meetings
- Farrier Workshops
- Roping Clinics
- Barrel Racing Clinics
- Horsemanship Workshops

These events would average 6-10 people, however the 4H and FFA Meetings can have up to 20 participants and their parents. In order to host these events, we would have to have an increased number in our animal count, but are willing to limit that number to 35 large animals. Please keep in mind that on average we will only have 25 animals. The additional number of 35 allows for transition when we are selling and buying new roping cattle. The number we would allow on our property will never exceed 50 large animals, and this includes the animals that members of the community will bring for events the day of and will generally be leaving that evening. Again, all of these will be at no cost to the community.

Our nuisance mitigation plan is as follows:

- All manure will be continued to be picked up daily, weather permitting, and loaded into the dump trailer which is hauled to Grey Wolf at least once a week.
- Fly traps will be hung around all livestock areas to help control the flies.
- The arena will be watered before every event so as not to cause any dust.
- There will be no outdoor lights installed at the arena.
- Events will end at 5:30 pm during winter months and 8:30 pm during summer months.
- The parking will be confined to our property.
- There will be no amplified speaker system.
- We will limit the number of overnight guests to two (2) and they will not be allowed to stay longer than ten (10) days. (This will meet the current Town Code) This will be a very rare occasion. It is much more likely we will have one (1) guest for the weekend.
- Property landscape will be always maintained.

We are looking forward to hosting our community for agriculture and western heritage events.

Regards,

Trampus and Bonnie Mansker



Sierra Lane

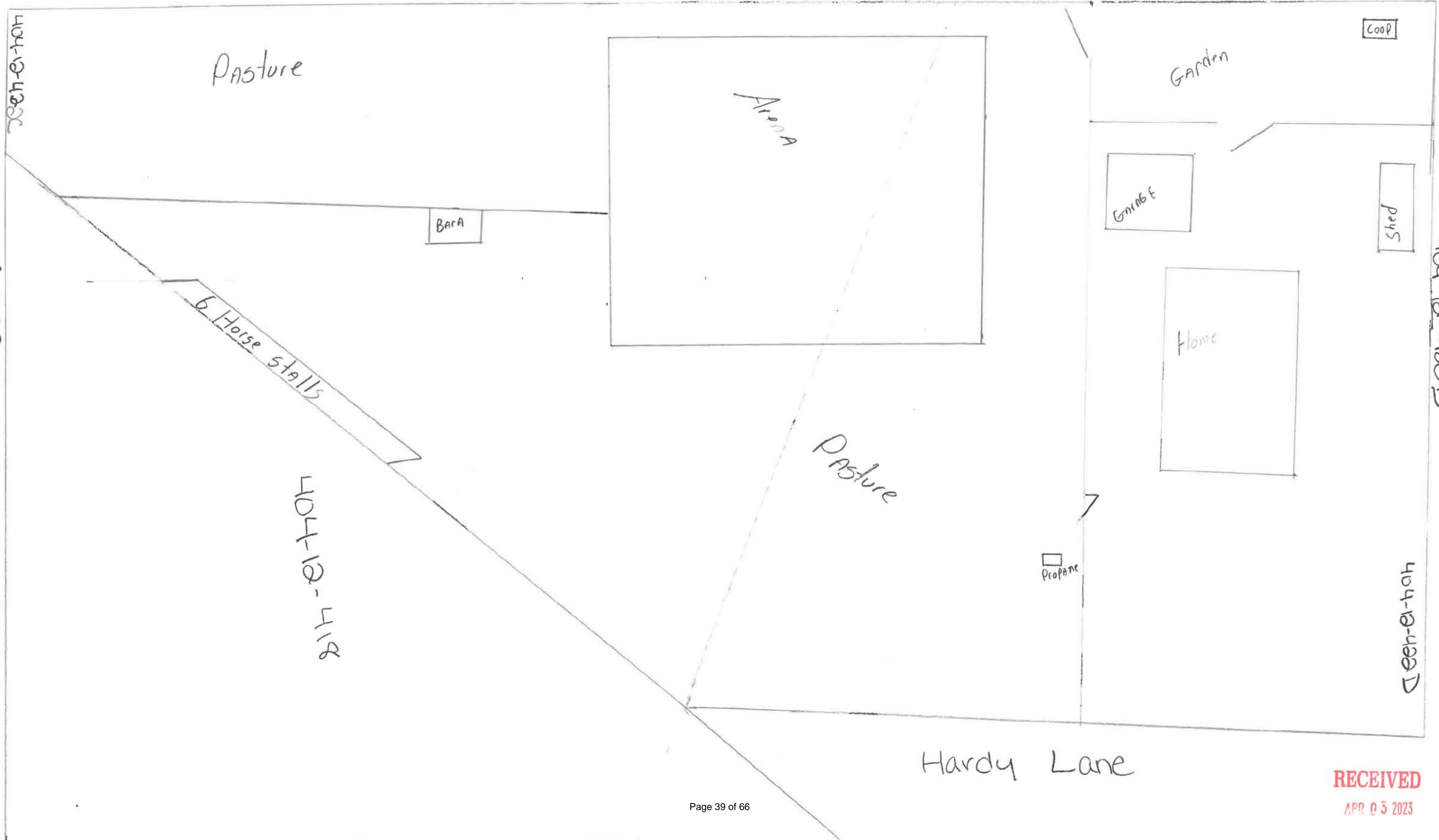

Hardy Lane

RECEIVED
APR 05 2023

Revised 06/05/18

Application #: 20230137

RR-2A
NO Flood

RECEIVED

MAR 7 2023



Land Use Application Form

1. Application is made for:

- | | | |
|---|---------------------|----------------------|
| Zoning Map Change | Use Permit | Temporary Use Permit |
| Conceptual Plan Review | Preliminary Plat | Final Plat |
| PAD Final Site Plan Review | Variance | Appeal |
| Street Abandonment | Minor Land Division | Wireless Tower |
| Administrative Review | Lot Line Adjustment | Zoning Verification |
| Development Standards Review (Commercial) | Other: _____ | |

2. Project Name: Mansker Agri-Tourism

3. Contact information: (a list of additional contacts may be attached)

Owner Name: <u>Trampus Mansker</u>	Applicant Name: <u>Trampus Mansker</u>
Address: <u>2083 E. Hardy Lane TL</u>	Address: <u>2083 E. Hardy Lane TL</u>
City: <u>Camp Verde</u> State: <u>Az</u> Zip: <u>86322</u>	City: <u>Camp Verde</u> State: <u>Az</u> Zip: <u>86322</u>
Phone: <u>[Redacted]</u>	Phone: <u>[Redacted]</u>
E-mail: <u>mansker2121@hotmail.com</u>	E-Mail: <u>[Redacted]</u>

4. Property Description: Parcel Number 404.12.42201/404.12.42200 Acres: 2.30/2.39 = 4.69

Address or Location: 2083 E. Hardy Lane Camp Verde Az 86322

Existing Zoning: _____ Existing Use: _____

Proposed Zoning: _____ Proposed Use: _____

5. Purpose: (describe intent of this application in 1-2 sentences)

We are applying for the AGR1-Tourism Permit, our goal is to Allow the youth to come + Learn About Wester Heritage

6. Certification:

I certify that I am the lawful owner of the parcel(s) of land affected by this application and hereby consent to this action. I have also attached a completed Permission to Enter form for consent to access the property regarding this action.

Owner: [Signature] Date: 10.19.22

I certify that the information and attachments I have submitted are true and correct to the best of my knowledge. In filing this application, I am acting with the knowledge and consent of the property owner(s). I understand that all materials and fees required by the Town of Camp Verde must be submitted prior to having this application processed.

Applicant: [Signature] Date: 10.19.22

RECEIVED
MAR 7 2023
20230137

Affidavit

I, Trampus Mangler, owner/agent of parcel 404.12.47221/404.12.47220 have notified the neighbors within 300' of above property, by sending letters on November 1st, 2022 to notify them of the neighborhood meeting that I conducted on the 16th day of November 2022.

I posted my property with meeting the date, time, and place, on the 1st day of November 2022, and taken a photograph of such posting.

I, Trampus Mangler, owner/agent of parcel 404.12.47221/404.12.47220 will provide a summary of neighborhood meeting I conducted to the Planning & Zoning Department of Camp Verde with the associated application submittal, attesting to the issues and concerns discussed at the above neighborhood meeting.

Summary Statement: See Attached

If Summary statement is too long, attach a copy.

State of Arizona}

County of Yavapai)

[Signature]
Signature of Document Signer No. 1

[Signature]
Signature of Document Signer No. 2

Subscribed and sworn to (or affirmed) before me this 7th day of March 2023.



[Signature]
Signature of Notary

Neighborhood meeting notes from November 17th.

Trampus read his neighborhood letter and explained his intentions with the Agritourism Permit.

Steve Magoon: Concerned about animal, traffic, lights and no recourse for complaining about animal counts, and that he has retained attorneys.

Trampus, replied that he is not in violation and he has an agreement with the city and his neighbors to put excess animals on there property.

Loraine, Stated we are a neighbor and don't mind what is going on, It does not bother us at all.

Tanner Bryson, Is in full support of Trampus and what he wants to do for the youth,

Christa Brunori, Asked what harm is it causing Mr. Magoon if the property is well kept?

Mr. Magoon replied and said they had to cancel a graduation party due to the flies.

Trampus let Mr. Magoon know he could move the animals further from his property and asked if that would help and Mr. Magoon declined.

Claudia Hauser, stood and said she is in full support of the Mansker Family and what we are trying to do for the youth.

Mr. Magoon argued about Town Ordiances with Claudia.

Mrs. Phelps- President of Camp Verde Arena Stated we have her full support and she will make sure that the right to farm bill will pass.

Bob Ashcroft, Trampus is my Neighbor I am in full support of Trampus and his family.

Christa, If You get this permit will Mr. Magoon still be able to complain?

Trampus, No Mr. Magoon can not complain about the animal count. He could only complain if I was not keeping up with the property. Or not following the laws of the application.

Linda serves on the county commission she met Trampus over irrigation issues and Trampus helped with the issue right away. I believe Trampus is a man of his word and she believes I am a good neighbor. She is in full support.

Rick Neighbor I have never experienced any issues with flies, smells or livestock. I am in full support of Trampus

Jordy, I would love to have someone like Trampus move next to us,

Tanner There should be a clause to fine people who complain too much.

Mr. Magoon I am not a constant complainer, I have only complained 5 times.

Becky, Thank you for being a kind neighbor and supporting our western lifestyle.

Montana I have never had flies,dust I have never heard noise I do not know anyone is there unless I go look. I am the closest neighbor.

Ari, I am in full support they will complain no matter what you have obviously tried to do everything you can.

**Neighborhood Meeting
Sign in Sheet**

PLEASE PRINT

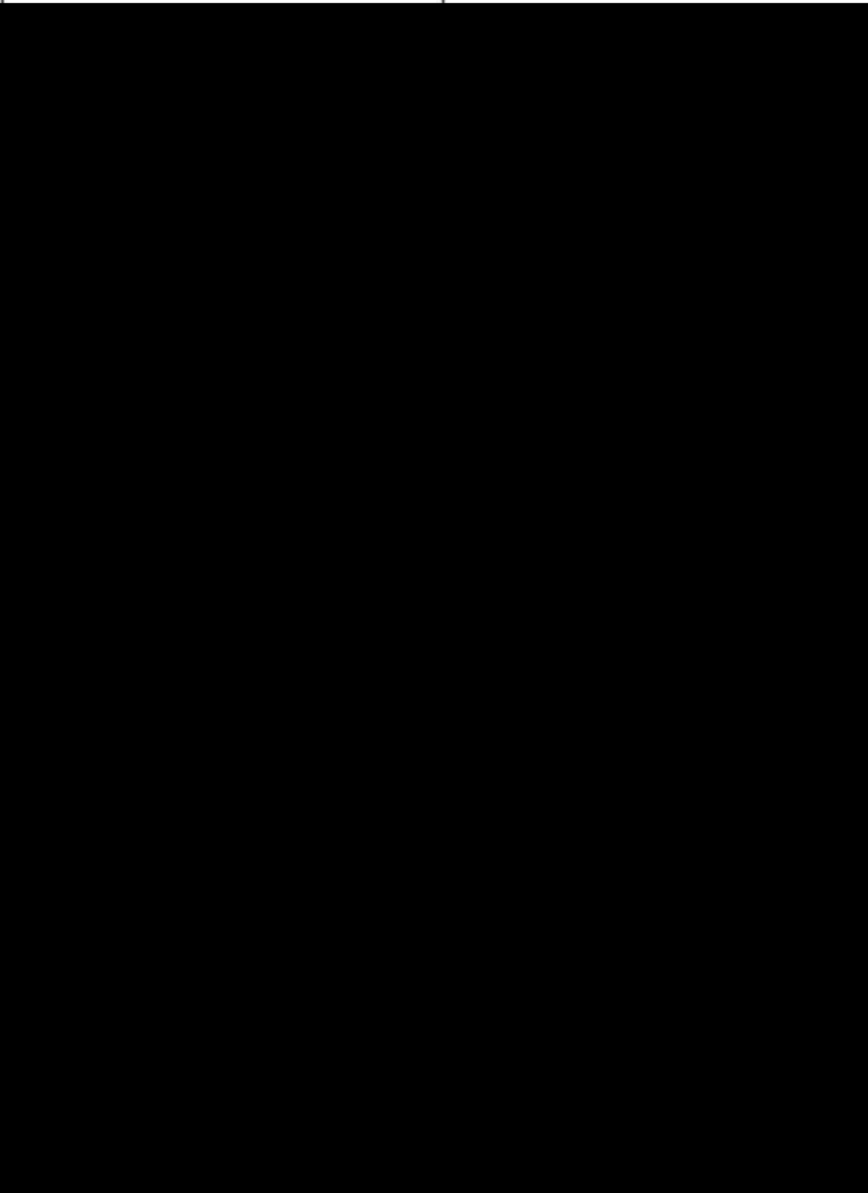
Name	Address	E-Mail
Herstel McCarty		
Carrie Stone		
Linda Buchanan		
Cory Mulcaire		
Dennis Seaton		
Josh Blair		
Dorie Blair		
Michael Black		
Ray Sandons		
Justin Jaffet		
Christa Brunari		

**Neighborhood Meeting
Sign in Sheet**

PLEASE PRINT

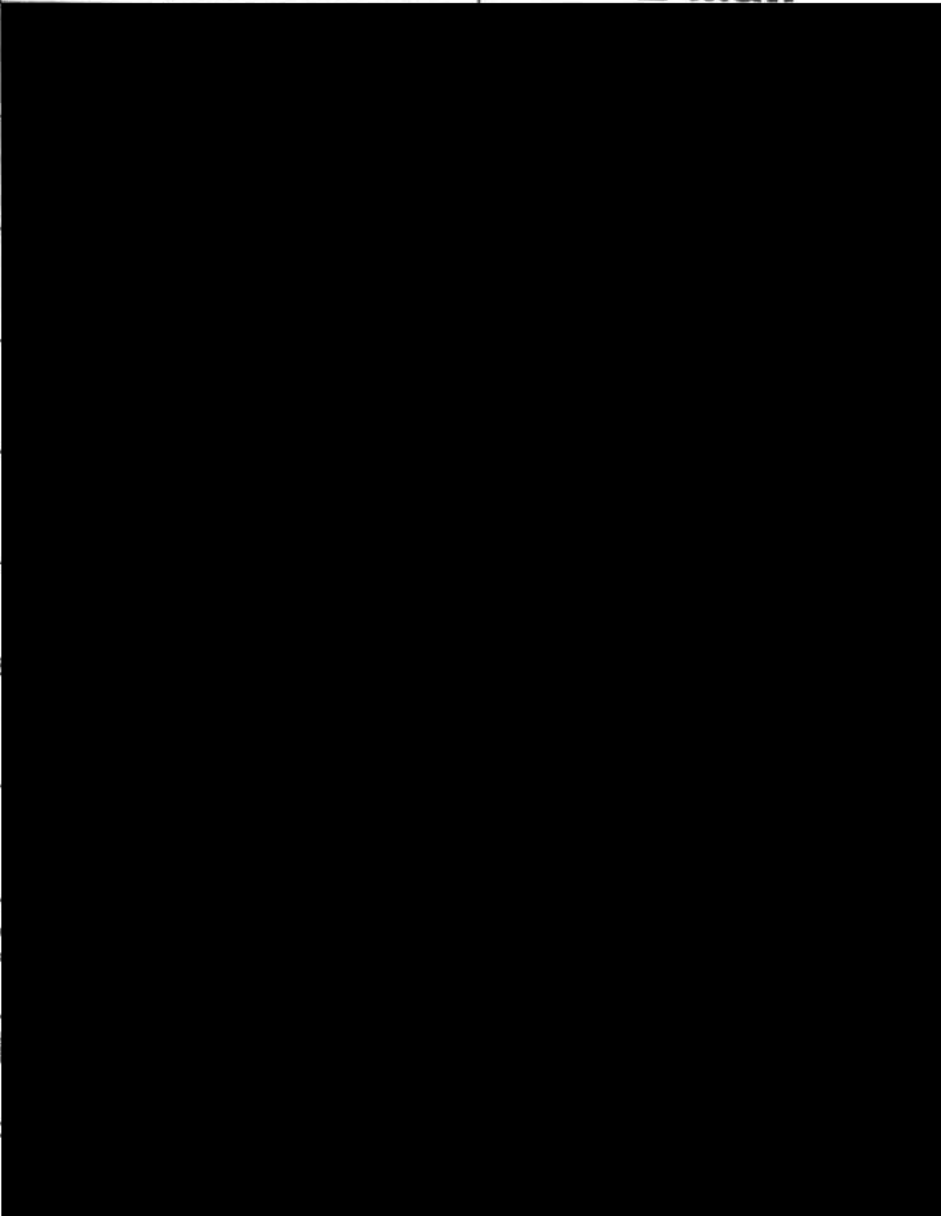
Name	Address	E-Mail
TANNER Bryson		
Rick Brent Beck		
Tye Reddell		
Tordy Weckert		
Claudia Hauser		
John K. Lacy		
Becky Rudd		
Jenna Medbeck		
Ariana Dodge		
Calvin Bahu		

November 1, 2022

Trampus and Bonnie Mansker

Re: Agritourism Permit Application

To Whom It May Concern:

We would like to invite our neighbors and interested parties to a neighborhood meeting.

- **November 17, 2022**
- **5:30 PM**
- **Camp Verde Public Library**

We are applying for an Agritourism permit for our property (APN 404-12-422D) to help increase the opportunities for youth in agriculture for the Town of Camp Verde. Our goal is to have a safe environment for families to come and learn about Camp Verde's agriculture and western heritage. At this time, we plan on having our local 4H-club host their workshops at our facility, which will only be a few hours during the day once a month. In addition, we will have some daytime horsemanship, farrier, and team roping clinics.

All clinics will be one day events, that are held during daylight hours. There will not be overnight or nighttime use. Clinics will be limited to a manageable number of participants, so that there will be no overflow parking or excessive traffic on the street. We will not be hosting contests of any type. There will not be a sound system installed on the property. We will continue to maintain our property as we already have, hauling manure to the dump weekly or more if needed.

We look forward to seeing everyone at the meeting.

Sincerely,

Trampus Mansker

ARENA PETITION

We, the undersigned support Trumpus and Boinnie Mansker Arena at 2083 E Hardy Ln. They should be able to operate as they are

Name	Address	Signature
Michael Bluck		M Bluck
Tamara Nieto		Tamara Nieto
Carol (Montana) Kenters		Carol Montana Kenters
Ariana Dodge		Ariana Dodge
Scott Stone		Scott Stone
Carrie Stone		Carrie Stone
Elaine EATON		Elaine Eaton
Herstel McCants		Herstel McCants
LEWIS PENDER		Lewis Pender
Ray Sanders		Ray Sanders
Michelle Bueler		Michelle Bueler
Cynthia Zellner		Cynthia Zellner
David Zellner		David Zellner
Judi Farr		Judi Farr
Polores Lucas		Polores Lucas
Calvin & Valerie Bell	Calvin & Valerie Bell	
Erica Benally	Erica Benally	

Signatures appeared herein is voluntary and no unlawful force contained upon specimen.

ARENA PETITION

We, the undersigned support Trumpus and Boinnie Mansker Arena at 2083 E Hardy Ln. They should be able to operate as they are

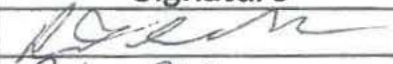
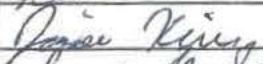
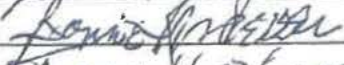
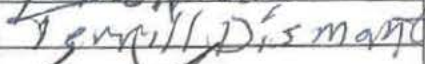
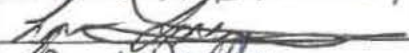
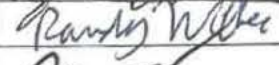
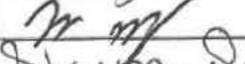
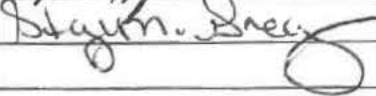
Name	Address	Signature
Rich Sherlock		
Jamie Kile		
Bonnie Anderson		
Kerry Dismant		
Lyman Lauthian		
Randy Wilber		
JAMES GREGORY		
Stacy Gregory		

Signatures appeared herein is voluntary and no unlawful force contained upon specimen.

To Whom it may Concern,

11/17/2022

We have Spent a lot of Time at the Monsker's home and the place is always well care for and Clean. They take great Care of their Animals and ensure the place is Clean & well groomed. This is a great family and we know they will take everyones Concerns into Consideration.

Thank you

Tordy Weaver

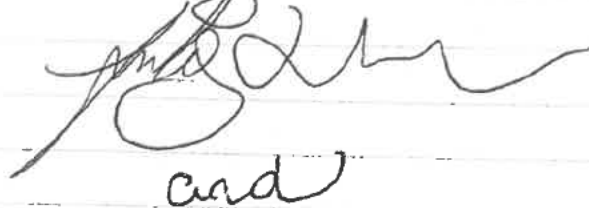

and

Tye Reddell



SECTION 103 - DEFINITION OF TERMS

For the purposes of this Zoning Ordinance, the following terms, phrases, words, and their derivations shall have the meaning given herein. Words, phrases, and terms not defined in this Zoning Ordinance shall be given their usual and customary meanings except where the context clearly indicates a different meaning. When not inconsistent with the context, words used in the present tense include the future, words in the plural number include the singular number, and words in the singular number include the plural number. The word "shall" is always mandatory and not permissive; the word "may" is permissive and not mandatory. Words used in the present tense include the future tense; words used in the future tense include the present tense. The word "person" includes individuals, partnerships, corporations, clubs, and associations and other forms of business enterprise. The following words or terms when applied to this Zoning Ordinance shall carry full force when used interchangeably; lot, plot, parcel, or premises; used, arranged, occupied, or maintained; sold or dispensed; construct, reconstruct, erect, place, or alter (structurally or otherwise), If more than one provision, standard, or requirement of any chapter of this Zoning Ordinance applies in all instances the most restrictive, provision, standard or requirement shall control.

DEFINED TERMS, PHRASES AND WORDS:

ABANDONMENT: The discontinuation of use for a period of one year.

ACCESSORY USE: A use of land or of a building or portion thereof customarily incidental and subordinate to and located on the same lot with the principal use.

ADJACENT: Adjoining or across a road from each other.

ADULT CARE CENTER: An establishment enrolling four or more adults where fees or other forms of compensation for the temporary care of the adults are charged, and which is licensed and approved to operate by the State.

AGRICULTURE: The production, keeping or maintenance, for sale, lease or personal use, of plants or animals useful to man, including the breeding and grazing of any or all of such animals; or lands devoted to a soil conservation or forestry management program. This includes farm stands for the temporary or seasonal sales of agricultural products grown on site or other grown on other properties owned or leased by the farm operator.

AGRITOURISM: Is the act of visiting a working farm, ranch, agricultural or horticultural agribusiness operation for the purpose of enjoyment, education or active involvement of visitors to experience a rural lifestyle. Visitors may participate in events and services related to agriculture which may take place on or off the farm or ranch, and that connect consumers with the heritage, natural resource or culinary experience they value. This may include but not limited to; farm stands or shops, U-pick, on-farm classes, fairs, festivals, pumpkin patches, wineries, barn dances, corn maze, hunting, fishing, guest ranches, agricultural tours, wildlife viewing or bird watching, wine tasting.

ALLEY: A passageway that has been dedicated or deeded for public use affording a secondary means of access to abutting property.

AMENDMENT: A change in the wording, context, or substance of these regulations or an addition, deletion, or a change in the zone boundaries or classifications upon the Zoning Map; Also a change in the wording, context, or other correction of a final plat.

SECTION 601 - ZONING DECISIONS

A. Zoning Ordinance Amendment Applications and Hearings

Any amendment to this Zoning Ordinance, which changes any property from one zone to another, imposes any regulation not previously imposed, or which removes or modifies any regulation previously imposed shall be adopted in the manner set forth in this section.

1. **Applications for Zoning Ordinance text amendments, rezoning amendments, Use Permits, or other requests** requiring Town Council approval shall be filed in the office of the Community Development Department on a form provided, along with such supplemental information required by the Department, and shall be accompanied by a fee established by approval of the Town Council. No part of any such fee shall be refundable after an application is filed and such fee paid, except at the discretion of the Town Council.
 - a. The Planning and Zoning Commission shall hold a public hearing within 90 days of the date of a complete application submittal. After such hearing the Council may adopt the recommendation of the Planning and Zoning Commission without holding a second public hearing provided there is no objection, request for public hearing or other protest.
 - b. The Town Council shall hold a public hearing if requested by the party aggrieved, any member of the public or of the Town Council, or in any case, if no public hearing has been held by the Planning and Zoning Commission.
2. **Notice of the time and place** of Council or Commission hearing shall be given in the time and manner provided for:
 - a. Notice of public hearing before the Commission or Council for all amendments to the Zoning Ordinance text, the zoning map, Use Permits, or other requests, shall be done in accordance with the provisions of Arizona Revised Statutes 9-462.04 as they exist now or as they are amended from time to time. Such notice includes at a minimum the posting and publishing of public hearing notices as specified in the statute.
 - b. Written protests of any recommendation action taken by the Commission shall be filed in the office of the Community Development Department before noon on the Monday of the week preceding the Council meeting at which such amendment will be considered. If such written protest constitutes twenty percent (20%) or more of the immediate area involved in a request for rezoning as specified in ARS 9-462.04.H, as may be amended, a favorable vote of three-fourths of the Council shall be required.
 - c. A decision made by the Council involving rezoning of land which is not owned by the Town and which changes the zoning classification of such land may not be enacted as an emergency measure and such a change shall not be effective for at least 30 days after the final approval of the change in classification by the Council.
 - d. In the event an application has been denied by the Council, the Commission shall not consider a similar application within 12 months of the application date.
3. **Citizen review and participation process** is required for all zone change applications or Use Permit applications:
 - a. Prior to any public hearing, the applicant or an appointed representative shall arrange a meeting with the planning staff which identifies development issues as well as arrangements and scheduling for the neighborhood meeting described in subsection b below.

- b. The applicant or an appointed representative shall conduct a neighborhood meeting designed to inform adjoining residents and property owners about the proposed zone change, specific plan application or Use Permit.
 - c. At least 15 days prior to the scheduled neighborhood meeting, the applicant shall notify all property owners within 300 feet of the subject site by first class mail and post the actual property with meeting date and time. The notification shall include the date, time and place for the neighborhood meeting, as well as a description of the proposed land uses. The applicant shall provide an affidavit attesting to this notification being accomplished.
 - d. It is the responsibility of the applicant or their representative to conduct the meeting, provide an opportunity for a question and answer period by the audience, and identify a point of contact to the public for follow-up questions and comments.
 - e. The applicant shall prepare a written summary of the meeting by way of affidavit, including a list of attendees and the issues and concerns discussed and submit a copy of the summary, with a photo of the posting on the property and a copy of the meeting announcement letter, to the Planning Department within 15 days after the neighborhood meeting.
4. **Zoning Ordinance text amendments:** If the Town adopts any zone change or any amendment that imposes any regulation not previously imposed or that removes or modifies any such regulation previously imposed, it must comply with the citizen review process as set forth in ARS §9-462.03, as may be amended, and the public hearing notice procedures set forth in ARS 9-462.04.A as may be amended.

B. Site Plan Review and Development Standards

Key to obtaining compliance with the regulations of this ordinance and achieving the objectives of the Town's General Plan is the administrative review of Site Plans for new development as regulated in Part 4 Development Standards. The Site Plan entails preparation of drawings for proposed uses and buildings that conform to the Development Standards, depicting adequate grading/drainage and Appearance Compatibility (Section 402), landscape and screening (Section 402), parking and loading (Section 403), signs (Section 404) and outdoor lighting (Section 405) as required in these regulations.

The Site Plan Review process is administered by the Community Development Department in conjunction with other Town departments. The Community Development Director is authorized to approve minor modifications to strict adherence of zoning regulations due to physical constraints of the project site. Appeals may be scheduled for hearing by the Board of Adjustment and Appeals. Major development projects may also be referred to the Commission and Council for a hearing, review and approval, which hearing and review process is mandatory if so stipulated by prior Council action such as rezoning or PAD approval.

For non-residential and multi-family developments as described in Section 400B, additional review of Appearance Compatibility Drawings is required (Section 402 C). Appearance Compatibility Drawings are reviewed by Town staff simultaneously with the Site Plan Review process, in accordance with the process specified in Section 400C.

C. Use Permit Approvals

Use Permits are provided to ensure the orderly use of land in conformance with the General Plan and applicable Town standards where uses are proposed that may require special limitations or conditions to provide compatibility with other uses. The application for Use Permit approval is applicable to those uses that are specifically listed as "Uses and Structures Subject to Use Permit" in each Zoning Use District in Part Two Section 203.

- 1. Review and Approval

- a. Use Permits will be granted only upon a finding by the Council that the use covered by the permit, the manner of its conduct, and any structure which is involved, will not be detrimental to persons residing or working in the vicinity, to adjacent property, to the neighborhood, or to the public welfare in general, and that the use will be in conformity with any conditions, requirements, or standards prescribed by the Town Code or Council.
- b. Use Permits may contain specific limitations on the scope, nature and duration of the use, as deemed proper in accordance with the following criteria:
 - 1) Any significant increase in vehicular or pedestrian traffic;
 - 2) Nuisance arising from the emission of odor, dust, gas, noise, vibration, smoke, heat, or glare at a level exceeding that of ambient conditions;
 - 3) Contribution to the deterioration of the neighborhood or to the downgrading of property values which, is in conflict with goals, objectives or policies of the General Plan;
 - 4) Compatibility with existing surrounding structures and uses; and
 - 5) Adequate control of disruptive behavior both inside or outside the premises, which may create a nuisance to the surrounding area or general public.
- c. The burden of proof for satisfying the above requirements shall rest with the applicant. A refusal of a Use Permit shall not be interpreted as the denial of right, conditional or otherwise.
- d. Where an application involves a definite development scheme, the applicant must submit a layout and landscape plan, building elevations and other pertinent data as may be requested, and the Council may condition the Use Permit to fully carry out the provisions and intent of the Zoning Ordinance.
- e. The Use Permit is valid and operable only for the specific use as granted and subject to any specified time limit. No use may be modified, changed, altered or increased in intensity, in any manner that conflicts with the Use Permit and/or required conditions of approval, without approval of a new Use Permit.

Within 30 days of any change, permittees shall notify the Community Development Department of any changes.

2. Duration and Voiding of Use Permit

- a. To secure the objectives of this Zoning Ordinance, Use Permits may be for a fixed time period, and a Use Permit does not grant a vested right beyond the term of the permit.
- b. The permittee must obtain building permits within six months from the date the Use Permit was issued. Failure to obtain a building permit or begin the use shall void the permit unless a delay to start the construction has been granted or an extension has been applied for with the Community Development Director prior to the expiration of the six-month period. Additional extensions must go to Council.
- c. If the use or uses for which a Use Permit has been granted are discontinued for a continuous period of six months, the Use Permit is voided.
- d. Violation of the terms of the Use Permit or this Zoning Ordinance voids the Use Permit.
- e. Decisions by the Community Development Director, which result in the voiding of the Use Permit, may be appealed to the Board of Adjustment and Appeals; subject to an application for appeal being on file in the Community Development Department within 30 days of notification of the Use Permit being voided.

B. D. R-R DISTRICT (Residential-Rural), (Formerly RCU)

1. Purpose:

The R-R District is intended to provide a zoning classification for portions of the incorporated area of Camp Verde not presently characterized by urban uses, and to provide for rural, large lot residential uses. Manufactured, Modular or Site Built. Mobile Homes Prohibited (See Part 3 Section 306.B.1.b.3).

Permitted Uses and Structures:

- a. Accessory Dwelling Unit (ADU).
- b. Agriculture and cultivation.
- c. Bed and Breakfast.
- d. Community parks, playgrounds or centers.
- e. Dwelling unit for one family on any one lot (See D.1).

Educational institutions (including private schools, provided they offer curriculum of general instruction comparable to similar public schools).

- f. Flood control facilities.
- g. Golf courses with accessory uses such as pro shops, shelters, and rest rooms.
- h. Historical Landmarks.
- i. Home occupations (See Section 303).
- j. Keeping of farm animals, limited (See Section 305).
- k. Open land carnival and recreation facilities (religious & educational institutions).
- l. Other accessory uses commonly associated with primary permitted use. (See Section 301 C.)
- m. Religious institutions (in permanent buildings).

2. Uses and Structures Subject to Use Permit

- a. Government facilities and facilities required for the provision of utilities and public services.
- b. Veterinary Services.
- c. Mobile/manufactured home and recreational vehicle parks subject to the requirements of Section 306.

1) Notwithstanding the foregoing, in the event a Planned Area Development (PAD) District is established per Section 203, this use may be included in any Development Plan thereunder and approved without being subject to a Use Permit application and hearing procedures set forth in Section 601.

d. Temporary Use Permits, subject to administrative approval (See Section 601.C):

- 1) Occupancy of temporary housing, including travel trailers, during the construction of a permanent dwelling is allowed during the 12-month period after issuance of a building permit.
- 2) Model homes, temporary offices (construction and pre-construction sales offices/showrooms), construction sheds and yards incidental to a recorded residential development or other construction project (subject to District setbacks) for a period not to exceed 12 months.

e. All uses with a valid Use Permit for expanded uses, including those uses listed in items a.-d., above, in effect as of June 24, 2011 will retain all rights associated with the Use Permit for the term of that Use Permit. Prior to the expiration of the said Use Permit, the owner may apply for a Use Permit, subject to all the requirements of Section 601.A-C, to continue the existing uses and any proposed new uses at the sole discretion of and as may be modified by the Town Council. (Ord 2013 A388).

f. Agri-Tourism, Application submission, required information, procedures and review are subject to Use Permit and criteria and specific showings of:

- 1) Adequate points of direct ingress and egress for patron safety and direct emergency vehicle access;
- 2) Ample on-site parking for normal business activity and provisions for special event overflow parking;
- 3) Adequate separation distance limitation of hours of operation, and/or additional measures to mitigate negative effects of lighting, noise, traffic, dust and other detrimental environmental factors on nearby residential uses or vacant residentially zoned property.
- 4) Provision for patrons' health, safety and comfort including but not limited to shade, first aid and water stations, sanitary facilities, food and beverages, trash receptacles/removal, and appropriate security.

5) A full two (2) acres (87,120 square feet) parcel is required to obtain a Use Permit for Agri-Tourism (Ord 2015 A206).

Table 2-4: R-R Dimensional Standards	"R-R"
Minimum Lot Area (sq.ft.)	87,120' (2 acres)
Minimum Width OR Depth (feet)	225'
Maximum Bldg Ht (stories)	2
Maximum Bldg Ht (feet)	30'
Maximum Lot Coverage (%)	15%
Minimum Front Yard (feet)	50'
Minimum Rear Yard (feet)	50'
Minimum Side Yard Interior (feet)	25'
Minimum Side Yard Exterior (feet)	30'

Table 2-4: R-R Dimensional Standards

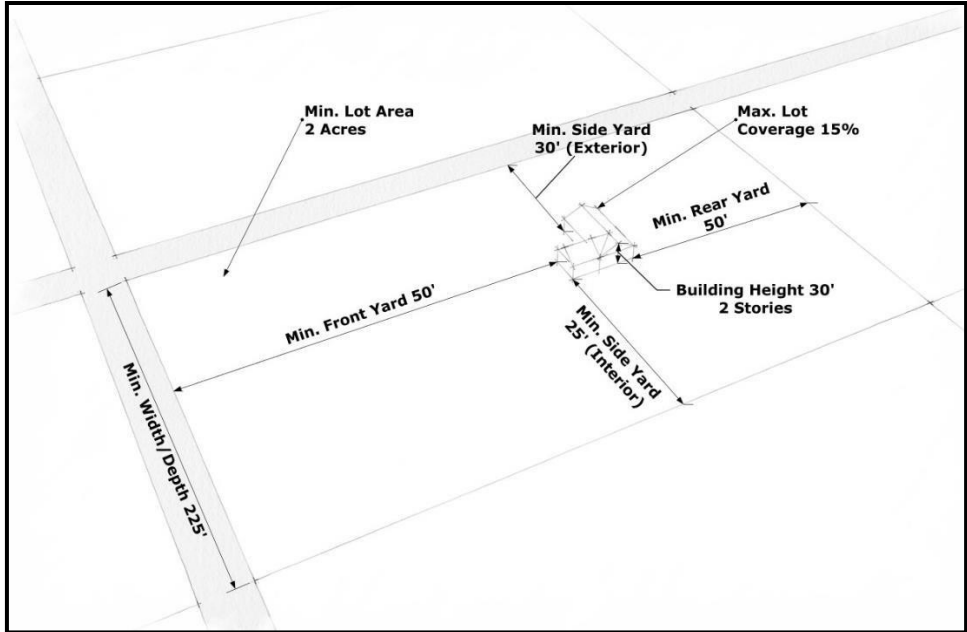

ATTACHMENT F

Yavapai County Print Parcel

	Parcel ID	Check Digit	
	404-12-422C	1	
	Owner	Mansker Trampus & Bonnie RS	
	Owner's Mailing Address	2083 E Hardy Ln Camp Verde, AZ 86322-6213	
	Secondary Owner		
	Recorded Date	2/7/2008 12:00:00 AM	
	Last Transfer Doc Docket	Last Transfer Doc Page	
	4572	991	
	Physical Address	Incorporated Area	
	2083 E Hardy Ln	Town of Camp Verde	
Assessor Acres	Subdivision	Subdivision Type	
2.3	N/A	N/A	
School District	Fire District		
Camp Verde Unified SD #28	Copper Canyon Fire And Medical		
Improvements (0)	Local Zoning		
No Improvements found.	Town Of Camp Verde RR-2A		
Assessment			
Starting with the 2015 tax year, the Limited Property Value is the only value considered for taxation purposes, the Full Cash Value is no longer used for taxation.			
Tax Year	2024	2023	
Assessed Value(ALV)	\$10,629	\$10,123	
Limited Value(LPV)	\$70,860	\$67,486	
Full Cash(FCV)	\$195,979	\$200,377	
Legal Class	Vacant or Other	Vacant Or Other	
Assessment Ratio	15%	15%	
Usage Code	0011 ?	0011 ?	
Taxes			
Tax Area Code	2022 Taxes Billed		
2877	\$1,050		
Recorded Documents & Sales (4)			
Date	Book/Page	Type	Cost
4/2/2021	2021-0023800	Warranty Deed	\$459,500
4/2/2021	2021-0023799	Death Certificate	\$0
2/7/2008	4572-991	Other - Sale	\$0
9/15/2005	4311-629	Other - Sale	\$0
Disclaimer: Map and parcel information is believed to be accurate but accuracy is not guaranteed. No portion of the information should be considered to be, or used as, a legal document. Users should independently research, investigate and verify all information.			
By using this website, the user knowingly assumes all risk of inaccuracy and waives any and all claims for damages against Yavapai County and its officers and employees that may arise from the use of this data and agrees to indemnify and hold harmless Yavapai County and its officers and employees to the fullest extent permitted by law. By using this website, the user also agrees that data and use of this website may not be used for commercial purposes.			

Yavapai County Print Parcel



Parcel ID	Check Digit
404-12-422D	0
Owner	
Mansker Trampus & Bonnie RS	
Owner's Mailing Address	
2083 E Hardy Ln Camp Verde, AZ 86322-6213	
Secondary Owner	
Recorded Date	
2/7/2008 12:00:00 AM	
Last Transfer Doc Docket	Last Transfer Doc Page
4572	991
Physical Address	Incorporated Area
N/A	Town of Camp Verde

Assessor Acres	Subdivision	Subdivision Type
2.39	N/A	N/A
School District	Fire District	
Camp Verde Unified SD #28	Copper Canyon Fire And Medical	
Improvements (3)	Local Zoning	

Type: Affixed Mobile Home
Year Built: 1999
Floor area ?: 1765
Multi Level: No
Below Grade Area ?: None
Basement ?: No

Type: Garage
Year Built: 2002
Floor area ?: 1120
Multi Level: No
Below Grade Area ?: None
Basement ?: No

Type: Mobile Home Yard Improvements
Year Built: 2002
Floor area ?: 1
Multi Level: No
Below Grade Area ?: None
Basement ?: No

Town Of Camp Verde
RR-2A

Assessment

Starting with the 2015 tax year, the Limited Property Value is the only value considered for taxation purposes, the Full Cash Value is no longer used for taxation.

Tax Year	2024	2023
Assessed Value(ALV)	\$14,157	\$13,482
Limited Value(LPV)	\$141,566	\$134,825
Full Cash(FCV)	\$257,107	\$258,945
Legal Class	Primary Residence	Primary Residence
Assessment Ratio	10%	10%
Usage Code	0819 ?	0819 ?

Taxes

Tax Area Code	2022 Taxes Billed
2877	\$1,179

Recorded Documents & Sales (5)

Date	Book/Page	Type	Cost
4/2/2021	2021-0023800	Warranty Deed	\$459,500
4/2/2021	2021-0023799	Death Certificate	\$0
2/7/2008	4572-991	Other - Sale	\$0
9/15/2005	3914361	Warranty Deed	\$500,000
8/15/2005	4311-629	Other - Sale	\$0

Disclaimer: Map and parcel information is believed to be accurate but accuracy is not guaranteed. No portion of the information should be considered to be, or used as, a legal document. Users should independently research, investigate and verify all information.

may arise from the use of this data and agrees to indemnify and hold harmless Yavapai County and its officers and employees to the fullest extent permitted by law. By using this website, the user also agrees that data and use of this website may not be used for commercial purposes.

ATTACHMENT G
PROPOSED DRAFT – Updated 4/6/2023

Conditions of Approval for Mansker Agritourism Use Permit

1. The applicant shall comply with the requirements contained in the submitted project narrative and application materials, unless modified by these conditions.
2. This permit shall run with the land in perpetuity, unless the use is discontinued for a period of six (6) months, or the permit is voided according to procedures outlined below.
3. Unless modified by these conditions, or the narrative and application materials, the applicant shall comply with all town code, zoning ordinance, and other laws and requirements. This includes obtaining building permits for all new improvement, as required by the Chief Building Official and Building Code.
4. Weather permitting, manure piles shall be removed from the property weekly to control odor and insects. Manure stored on site in a trailer shall be tarped to reduce insects.
5. Fly traps shall be hung around the perimeter of all livestock pens to help control insects. Traps shall be replaced as needed for maximum effectiveness.
6. If dry, the arena shall be watered with an arena sprinkler system before every major use in order to control dust.
7. All outdoor lighting shall to be Dark Sky compliant. If required for new fixtures, building permits shall be obtained prior to installation of any new lighting.
8. Any lighting of the arena, and surrounding area, shall be turned off at the end of the event or by 10:00 p.m., whichever comes first.
9. The number of event attendees shall be limited by the available onsite parking and shall not exceed a maximum of 60 individuals at a single event.
10. There shall be no amplified sound systems used for any events.
11. For visitors health, safety and comfort, the applicant shall provide shade, first aid and water stations, sanitary facilities, food and beverages, trash receptacles/removal, and appropriate security during events.
12. Use of RVs on the site shall be limited to a (10) day maximum stay in compliance with the Zoning Ordinance.
13. The applicant shall comply with Section 10-2-1 of the Town Code (Declaration of Nuisance) which states:

Property and Hazards: *No use or structure shall be operated or maintained in such a manner as to be an explosive or fire hazard; nor cause smoke, soot, dust,*

radiation, odor, noise, vibration, heat, glare, toxic fumes or other negative impact on the community to be emitted into the atmosphere at any time to such an extent as to constitute a nuisance; contribute to neighborhood deterioration; nor divert water-carried waste or pollutants into any open water course or groundwater supply. Any such condition determined by the Town to constitute imminent peril to public health, safety or welfare shall be ceased immediately.

14. Town staff shall be allowed to enter the property to investigate complaints received that are related to use of the property. These may include, but are not limited to, noise, odor, dust insects, and other potential nuisances. Town inspections will only be performed to investigate potential violations of this use permit, zoning ordinance, or other town ordinances. Town staff shall provide advance notice to and coordinate with the property owner or manager to schedule inspections.
15. The number of large animals (such as horses and cattle) shall be limited to a maximum of 35 at any time, including overnight. The maximum number of smaller animals, such as sheep and goats, shall not exceed 50 for events. At night, the number of smaller animals shall be in compliance with the animal point counts allowed under Section 305.B. of the zoning ordinance.
16. If there are more than two (2) violations received against this property related to non-compliance with the approved conditions, zoning ordinance, or town code, during a six (6) month period, the Agritourism Use Permit may be modified or voided according to the procedures contained in Section 601.C.2. of the zoning ordinance. Should this occur, the Community Development Director shall notify the permittee, by regular First-Class mail, of a violation or possible termination/modification of the use permit. If no attempt to change the violation is made within thirty (30) days after notification, a hearing will be scheduled before the Board of Adjustment and Appeals. Based on information provided at the hearing related to non-compliance, the Board may modify or void the Use Permit. Modifications could include new or additional mitigation measures to address nuisance impacts. Modifications could also include a decrease in the maximum animal count.
17. This Agritourism Use Permit shall be reviewed by the Town Council one (1) year from approval for compliance with the conditions and requirements of the use permit. The permit shall then be reviewed thirty-six (36) months from issuance. At time of review, the council may increase or decrease the number of animals, modify or add conditions to address nuisance impacts.
18. Any other modifications to the use permit shall be subject to submittal of a new use permit in accordance with the procedures outlined in Section 601.C. of the zoning ordinance.

Attachment H

Active Agritourism Use Permits

Resolution	Information
2014-919	Jackpot Ranch, allowing for large events including family gatherings, weddings, group picnics, horse motel, equestrian events, charitable and civic events, corporate retreats, etc.
2015-946	Ignacio Mesa, operate a wine tasting room.
2017-982	Salt Mine Winery, operate a wine tasting room
2017-992	Animal Guardian Network, operates an animal sanctuary and healing ranch. Public can go on pre-arranged tours.
2018-1005	Nashwa Farms, event ranch



RESOLUTION 2014-919

A RESOLUTION OF THE COMMON COUNCIL OF THE TOWN OF CAMP VERDE, ARIZONA, YAVAPAI COUNTY, ON USE PERMIT 20140060, AN APPLICATION SUBMITTED BY MR. BILL MOORE, AGENT FOR THE SHUSTER FOUNDATION, OWNER OF JACKPOT RANCH LOCATED ON THE FOLLOWING PARCELS: 403-17-006K 64.75 ACRES AND 403-18-001H 2.43 ACRES AND 403-18-107C 4.94 ACRES FOR A TOTAL OF 72.12 ACRES. THE FOLLOWING PROPOSED USES ARE FOR THE ENTIRE 72.12 ACRES INCORPORATING ALL THREE PARCELS: HORSE MOTEL, CORPORATE, SPIRITUAL AND GOVERNMENTAL OVERNIGHT RETREATS, GROUP ACTIVITIES WHICH WOULD INCLUDE; WEDDINGS, FAMILY GATHERINGS, GROUP PICNICS, EQUESTRIAN EVENTS, CHARITABLE AND CIVIC EVENTS, ICE SKATING RINK AND MOBILE WESTERN TOWN LOCATED AT 2025 W. RESERVATION LOOP RD. MEETING FACILITY WITH KITCHEN & OUTDOOR ASSEMBLY AREA LOCATED AT 1879 W. CIMMARON DR.

The Common Council of the Town of Camp Verde hereby resolves as follows:

1. The Common Council hereby finds as follows:

- A. A request for approval of Use Permit 20140060 was filed by Mr. Bill Moore Agent for the Shuster Foundation owner of parcels 403-17-006K, located at 2025 W. Reservation Loop Rd., 403-18-107C location is vacant land with no address assigned & 403-18-001H located at 1879 W. Cimarron Dr. These parcels are zoned RR (Rural Residential) and the proposed uses are permitted under such zoning with a Use Permit.
- B. The request was reviewed by the Planning and Zoning Commission on April 03, 2014 and by the Common Council on April 23, 2014 in public hearings that were advertised and posted according to state law.
- C. A neighborhood meeting was held on March 18, 2014 by the applicant to provide for citizen review pursuant to ARS § 9-462.03 and as required by the Town of Camp Verde Planning & Zoning Ordinance, Part 6, Section 601 (Zoning Decisions) A.3.a-e.
- D. The purpose of the use will not constitute a threat to the health, safety, welfare or convenience to the general public and should be approved and the Council hereby finds that the uses covered by the Use Permit and the manner of its conduct will not be detrimental to persons residing or working in the vicinity, to adjacent property, to the neighborhood or to the public welfare generally and the uses shall be in conformity to the conditions, requirements and standards of the Town Planning & Zoning Code.

The following proposed stipulations would be in place:

- All Events are to end by 10:00 pm.
- Up to Six (6) large events (defined as 300 or more people) are allowed per year.
- Notification will be made to the neighbors, Community Development Department, Camp Verde Fire District and the Town Marshal's Office with the dates and times for any activity or event that will have 300 or more participants.

- The sound from amplified music must be minimized utilizing all of the following methods: A) Decibel Monitoring; B. Deflection of sound through the use of barriers; C. Aligning speakers in a location that would direct the sound away from the closest neighbors.
- All building modifications must be permitted, completed and a Certificate of Compliance issued by the Town before any of the approved activities may be conducted in new or modified facilities. A time limit to meet all compliance issues being 180 days after Use Permit approval or as determined by the Building Official as based on the owners progress of completion.
- The Use Permit requires the Octagon building which has been converted from a single family residence to a meeting and reception area to be properly permitted, with as built plans submitted by an Arizona Registered Design Professional including wet seal stamp on the as built plans certifying that the plans were followed, along with a list of all contractors, including Registrar of Contractors license numbers who performed the conversion work.
- The Use Permit requires the garage which has been converted from a utility building into a commercial kitchen to be properly permitted, with as built plans submitted by an Arizona Registered Design Professional including wet seal stamp on the as built plans certifying that the plans were followed, along with a list of all contractors, including Registrar of Contractors license numbers who performed the conversion work.
- The Use Permit requires the existing tree house to be properly permitted, with as built plans submitted by an Arizona Registered Design Professional including wet seal stamp on the as built plans certifying that the plans were followed.
- For all events over 300 or more people, and Event Plan will be submitted to the Community Development Department, Camp Verde Fire district and the Town Marshal's Office. The Event Plan shall include, but not limited to, a detailed description of what precautions and actions will be followed for the specific event in order to address the following critical concerns: Event Hours, Traffic Control Plan, Parking, Noise, Dust Abatement, Trash Service in the event and in the neighborhood, Sanitation, Security, and Emergency Services.

Maximum number events per calendar year based on number of visitors at each event. The number of authorized events in each calendar year is cumulative (e.g. in one calendar year an unlimited number of events with attendees of less than 50 could be held, plus two events with attendance between 300-499 could be held, and one event with attendance between 1250-1499 could be held.)

<u>Number of visitors</u>	<u>Number of events</u>
1-49	unlimited
50-149	25
150-299	4
300-499	2
500-749	1
750-999	1
1000-1249	1
1250-1499	1

This parking table will be utilized in determining appropriate parking for all events of 300 or more people:

Daily Visitors to Ranch	Maximum Estimate # of Vehicles	On-site Parking (including 10 handicap)	Off-Site Parking	On-Site Temporary Parking	Shuttle Service
0-250	150	212	N/A	N/A	N/A
250-500	300	212	N/A	N/A	N/A
500-700	450	212	260 +/-	815	N/A
750-1000	600	212	260 +/-	815	Possible
1000-1250	750	212	260 +/-	815	Possible
1250-1499	900	212	260 +/-	815	Possible

- **Mobile Western Town**

To include structures which will either be mounted on trailers or capable of being removed within a matter of hours:

Horseback Trails, Pellet gun shooting gallery, Cantina, Pony Express Depot, Cottonwood Gulch Jail, Livery Stable, Blacksmith Shop Pavilion, Catering trailer and Mineshaft with Gold Panning.

In the event that the applicant is unable to proceed with the above referenced facilities due to floodway considerations or any reason whatsoever, the following basic activities may be substituted to occur in the area down by the river (with or without any new structures): a) campfire subject to county/town burn restrictions, b) cowboy activities and games such as trick roping, tomahawk toss, horseshoes, gun spinning, etc., c) an area to picnic or eat meals likely on picnic tables, and d) non-amplified entertainment such as acoustic guitar, etc.

All of the requested uses to continue with no time limit, but are subject to the requirements of Part 6, Section 601 (Zoning Decisions), C. 1 & 2 of the Town of Camp Verde Planning & Zoning Ordinance.

PASSED AND ADOPTED AT A REGULAR SESSION OF THE COMMON COUNCIL OF THE TOWN OF CAMP VERDE, ARIZONA ON May 28, 2014.



Charles German, Mayor

Date: 6-11-2014

Approved as to form: 
Town Attorney

Attest:  - Deputy Town Clerk
Deborah Barber, Town Clerk